

Differential Current Relay DSR-8



**Monitoring of differential current for
generators, motors and transformers**

**Protective functions according to ANSI/IEEE C37.2:
87GP, 87MP, 87TP, 50N, 50G, 51, 81U, 81O**



Index

1	General Remarks	4
2	Safety Information	4
3	Measurement.....	5
3.1	Current Measurement.....	5
3.1.1	Internal Currents ($I_{1,Internal}$, $I_{2,Internal}$, $I_{3,Internal}$).....	5
3.1.2	External Currents ($I_{1,External}$, $I_{2,External}$, $I_{3,External}$)	5
3.1.3	Stabilised Currents.....	5
3.1.4	Differential Currents	6
3.1.5	Earth Current / Neutral Conductor Current (I_{Earth}/I_N)	6
3.2	Frequency Measurement.....	6
4	Installation	7
4.1	Mechanical Installation	7
4.2	Electrical Installation.....	7
4.2.1	Connection Diagram	7
4.2.2	Selection and Connection of the Current Transformers	8
4.3	Commissioning	9
4.3.1	Basic Settings	9
5	Handling and Operation	9
5.1	Overview of the Control Elements	9
5.1.1	Buttons	10
5.1.2	DIL Switches	10
5.1.3	LEDs.....	10
5.1.4	Graphic Display.....	11
5.1.5	USB Interface / Driver Install	11
5.2	Display View	12
5.2.1	Main Screen.....	12
5.2.2	Menu Structure	12
6	Configuration of the Device	17
6.1	Type of System.....	17
6.2	Nominal Values of the System.....	18
6.3	Current Transformer Setting	18
6.4	Transformer Setting.....	18
6.5	Measurement Range Selection	19
6.6	Configuration via GV-2	19
6.7	Editing at the Device.....	19
6.7.1	Protection of Input with PIN.....	19
6.8	Parameter Setting.....	19
6.8.1	Selecting of Groups and Parameters.....	20
6.8.2	Entering of a Value.....	21
6.8.3	Setting the Fault Message Coding.....	22
6.9	Setting of Time and Date	23
6.9.1	Via GV-2	23
6.9.2	Manually Setting of the Time.....	23
6.10	Language Selection and -Switching.....	24
7	Operation.....	24
7.1	Limit Values	24
7.1.1	Behaviour of the Limit Values.....	24
7.1.2	Tripping of Limit Values.....	24
7.1.3	Manually / Automatically Reset	25
7.1.4	Locking of Trippings	25
7.1.5	Locking Time.....	25
7.1.6	Central fault	25
7.1.7	Central fault 1+2.....	26
7.1.8	Display First Fault	26
7.2	Limit Value Setting.....	26
7.2.1	Rotary Field Protection.....	26
7.2.2	Differential Current Tripping	26
7.2.3	Overcurrent Tripping, stabilised Current	27
7.2.4	Overcurrent Tripping, internal Current	27
7.2.5	Overcurrent Tripping external Current	28
7.2.6	Overcurrent Tripping, Earth- / Neutral Conductor Current.....	28
7.2.7	Overcurrent Time Protection	28
7.2.8	Tripping of Frequency	29

10



7.3	Tripping Memory	29
7.3.1	Reading out the Tripping Memory	30
7.4	Programmable Switching Points	30
8	Inputs	31
8.1	Digital Inputs	31
8.1.1	Monitoring of the Relay- (Contactor-) Feedback	31
9	Outputs	32
9.1	Digital Outputs	32
10	Logic Functions	34
10.1	AND – Gate (1)	35
10.2	OR – Gate (2)	35
10.3	Exclusive OR – Gate (3)	35
10.4	AND-Not – Gate (4)	35
10.5	OR-Not – Gate (5)	35
10.6	Exclusive Not-OR – Gate (6)	35
10.7	Timer – pick up delayed	35
10.8	Timer – drop down delayed	35
10.9	Fault Message Assignment	36
10.10	Locking Functions and Automatic Reset	36
10.11	Functions for the Logic Modules	36
11	Technical Data	37
11.1	Triggering Values	37
11.2	Ordering Information	37
12	Connection Example	38
Annex 1	Parameter Groups	39
Annex 1.1	Configuration (Konfig. / Config – Group 1)	39
Annex 1.2	Limit Values (Grenzwerte / Limits – Group 4)	41
Annex 1.4	Digital Outputs (Digi. Ausg. / OUT – Group 6)	43
Annex 1.5	Digital Inputs (Digi. Eing. / IN – Group 7)	43
Annex 1.6	Logic Functions (Logik – Group 10)	44
Annex 2	Overcurrent-Time-Protection Curves	45

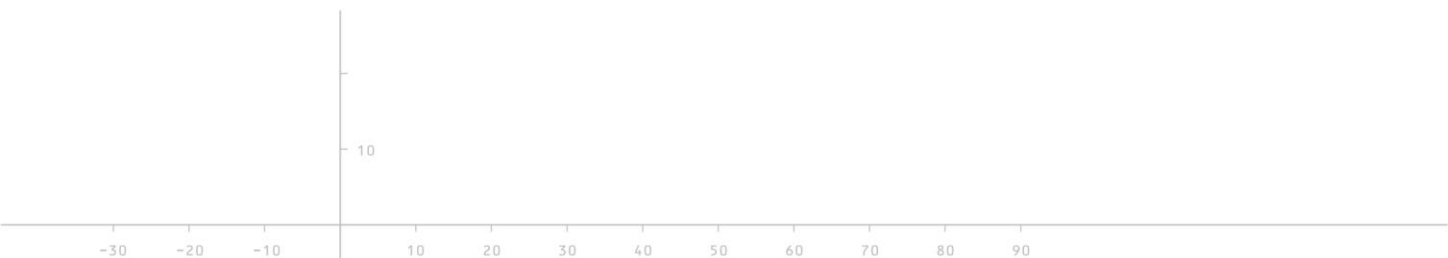



1 General Remarks

1

The DSR-8 is a device for measurement and monitoring of differential current at generators, motors and transformers. As well possible is the monitoring of mixed constructions, such as a generator with an upstream transformer. In addition to the differential current, it is also possible to measure the individual conductor currents as well as the earth current in three-wire networks. The connection to the plant must be done using external current transformers.

The DSR-8 includes the following protective functions [according to ANSI/IEEE C37.2]:

- Protection on differential current for generators, motors and transformers [87GP, 87MP, 87TP]
- (Earth-) overcurrent protection [50, 50N, 50G]
- Overcurrent-time-protection [51]
- Frequency monitoring [81U, 81O]

The comfortable configuration of all settings of the DSR-8 is done by means of the parameterisation software 'Geräteverwaltung' (GV 2 – Version V2.36 or later required). Alternatively values can be entered directly at the device. Any access to the device's parameterisation can be protected by a PIN. The output of display-texts at the device standardly takes place in German and English (switching between languages is possible at any time during operation). Alternative languages, suitable to the customers requirements, can be configured and conveniently made available, by means of our parameterisation software 'Geräteverwaltung'.

2 Safety Information



Caution! The following safety and installation instructions must be observed when handling the device:

- Installation and commissioning only by trained professionals.
- The user is responsible for checking the correct configuration of the DSR-8 before commissioning or maintaining the device.
- Maximum values given in this description must not be exceeded.
- The device must be disconnected from the mains during maintenance and installation.

The symbols shown in this description have the following meaning:

	The Caution symbol indicates possible injury or life hazards.
	Explanatory text or hint on special features at the handling or behavior of the device.

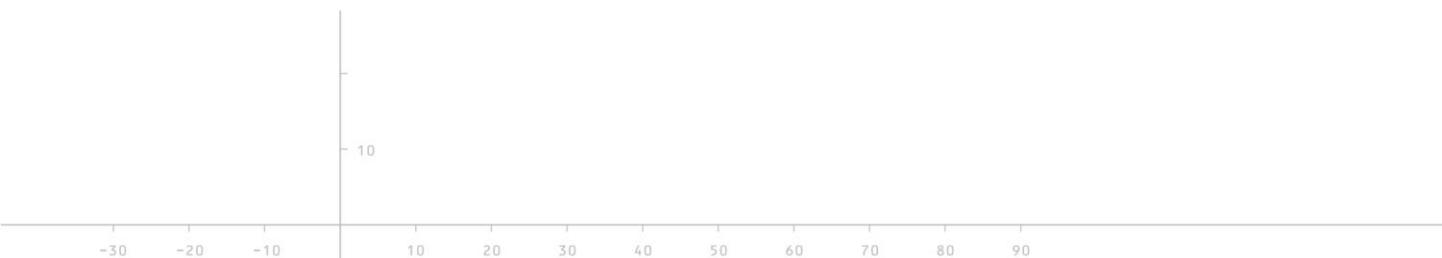



3 Measurement

Seven currents are simultaneously sampled and measured. The calculation of all other values is carried out on basis of the measured values. The frequency measurement is performed on phase L1 of the internal current.

3.1 Current Measurement

The current measuring is a true root mean square value measurement. It operates down to a current of approx. 30mA. The successful measurement at a phase (internal and external) is indicated by light up of the respective LED. The end of the measuring range of DSR-8 is amounted at 4 A (1 A Version) respectively 20 A (5 A Version).

The accuracy of the current measurement is better 0.2% of the final value.

The relative values are calculated on base of the set plant nominal current. This refers to the side of the external currents.

To illustrate the measuring values of current, the following figures show the designations of the currents at the object to be protected.

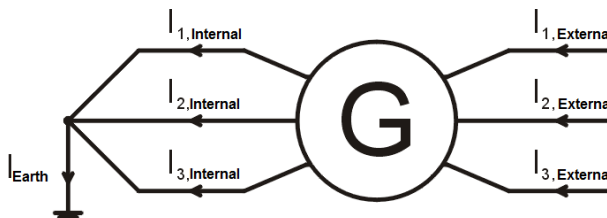

Note: When measuring currents on a star-delta transformer, the internal currents always refer to the side of the star winding. An incorrect connection leads to a wrong treatment of the star point and does not result in valid measuring values.

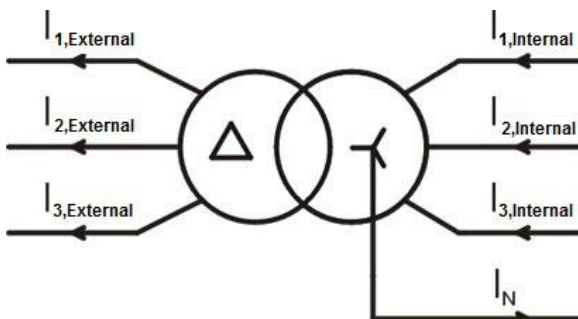

3.1.1 Internal Currents ($I_{1,Internal}$, $I_{2,Internal}$, $I_{3,Internal}$)

The internal currents are measured directly per phase. The measured value is present as percentage value of the nominal current and as absolute value.

3.1.2 External Currents ($I_{1,External}$, $I_{2,External}$, $I_{3,External}$)

The external currents are measured directly per phase. The measured value is present as percentage value of the nominal current and as absolute value.

3.1.3 Stabilised Currents

The stabilised currents are respectively the average values of internal and external current per phase and are calculated from these. The measuring value is present as percentage value of the nominal current. The displaying as an absolute value is only possible for plant configurations without transformer. The calculation is based on the following formula:

$$I_{stabilised,n} = \frac{I_{internal,n} + I_{external,n}}{2}$$

10



3.1.4 Differential Currents

The differential currents are respectively the differences of internal and external current per phase and are calculated from these. In doing so, the phase position is corrected by a possibly parameterised displacement angle (switching group). The measuring value is present as percentage value of the nominal current. The displaying as an absolute value is only possible for plant configurations without transformer. The calculation is based on the following formula:

$$I_{Difference,n} = I_{internal,n} - I_{external,n}$$

3.1.5 Earth Current / Neutral Conductor Current (I_{Earth}/I_N)

The earth- respectively neutral conductor current (depending on parameterisation) is measured directly. Depending on the configuration, this is displayed as I_N (neutral current) or I_E (earth current).

3

3.2 Frequency Measurement

The frequency of the five currents separately recorded and evaluated. The frequency measurement begins at a current of approx. 50 mA (secondary sided) and takes place in the range of approximately 15.0 cy to approx. 100.0 cy. The accuracy is better than 0,01 cy absolute.



Note: If due to a too low measuring current no frequency measurement is carried out, the DSR-8 operates with the nominal frequency (50 or 60 cy), which is set by parameterisation (see chap. 6.8).





4 Installation

**Assembly and commissioning only by trained professionals,
Connection in compliance with VDE 0160.**

4.1 Mechanical Installation

The DSR-8 is designated for a mounting on a 35 mm top-hat rail, according to DIN EN 60715. The installation width is approx. 100 mm.

4.2 Electrical Installation

Assembly and commissioning only by trained professionals.



Selecting the cables and the electrical connection of the device, the regulations of the VDE 0100 "Regulations for the Setting up of Power Installations with nominal Values below 1000 V", the VDE "Equipment of Power Installations with Electrical Components" resp. the respective national / local regulations must be observed.

The electrical connection has to be carried out only by trained professional staff (VDE 1000 T. 10).

The device must be disconnected from the mains during maintenance and installation work.

4.2.1 Connection Diagram

An example of a possible wiring is shown in chapter 12 'Connection Example'.

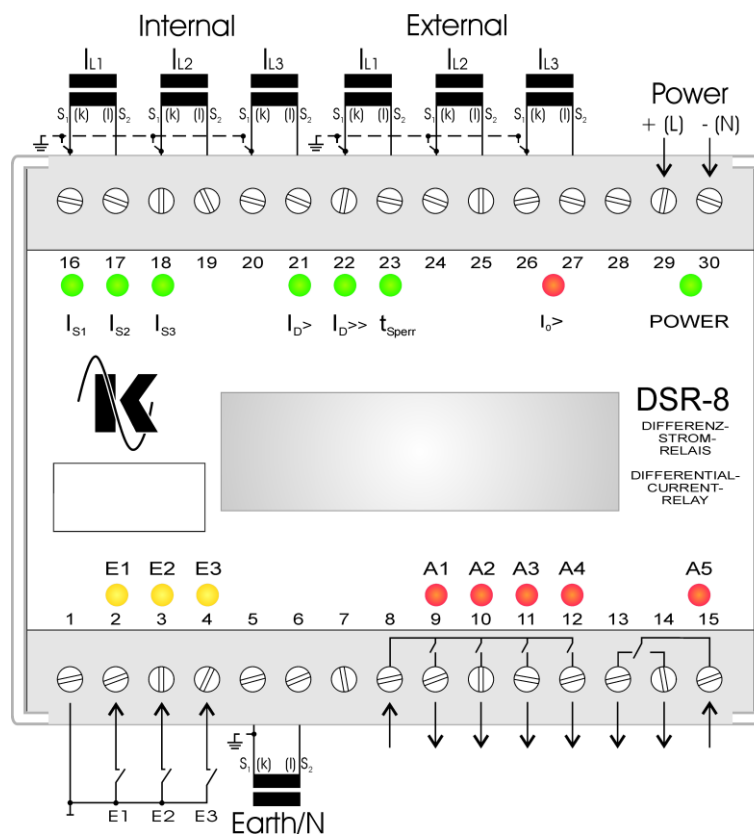



4.2.2 Selection and Connection of the Current Transformers



**At all work on the current transformers, these must be short-circuited!
Each current transformer must be grounded on one side!
Operation of the DSR-8 without interposed current transformers is prohibited!**

It is advisable to select the current transformers to be used so, that, in the case of the system nominal current on the primary side, the nominal current of the DSR-8 (1 A or 5 A variant) flows on the secondary side of the current transformers. A deviating configuration can lead to decrease accuracy and measuring range.

If the protection area includes a transformer, internal and external current are to be considered separately and the current transformers are to be selected accordingly.

Example:

DSR-8 (1 A variant)

Protection range	Transformer
Nominal current plant (primary/external)	100 A
Primary voltage	800 V
Secondary voltage	400 V

For the current transformers at the external side applies: 100 A nominal current must be converted to 1 A measuring current.

→ Converter ideal 100 : 1 (external)

For the internal side, a nominal current of: $100 \text{ A} \cdot (400 \text{ V} / 800 \text{ V}) = 50 \text{ A}$ arises as a result. This nominal current must be converted to 1 A measuring current.

→ Converter ideal 50 : 1 (internal)

The current transformers for the internal and external current must be connected in such a way that they all have the same sense of direction (for example, S1 terminal internally always to the star point). A connection contrary to this specification can lead to fault releases of the device.

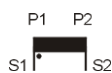

Correct ✓

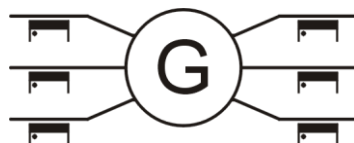

→ All current transformers are connected as described.

False ✗

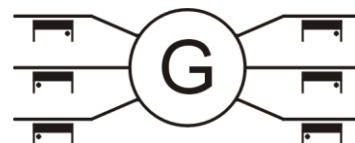

→ The current transformers do not have all the same current direction, both under the three conductors and on one conductor (internal – external).

Correct ✓

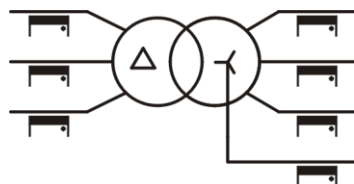

→ All current transformers are connected as described.

False ✗

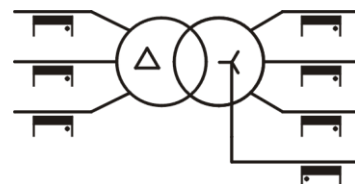

→ The current transformer of the neutral conductor has the wrong orientation.



4.3 Commissioning

For putting the DSR-8 into operation, it is to connect as per connection diagram (see chap. 4.2.1). The device is factory calibrated and pre-set with default settings.

4.3.1 Basic Settings

At the first start-up, settings must be made to adapt the DSR-8 to the respective plant (see chap. 6 – Configuration of the Device). This includes the nominal current, nominal frequency, type of the plant as well as the converter ratios of the individual current transformers. The settings can be done by the supplied, respectively for downloading on our Homepage www.koralewski.de available parameterisation software 'Geräteverwaltung GV-2'. The modification of operating settings by direct input at the device is possible as well (see chap. 6.7 – 'Editing at the Device' and following).

5 Handling and Operation

The DSR-8 is served by means of 2 buttons as well as 4 DIL switches, which can be reached after removal of the front lid.

Using the USB interface, the parameterisation can be carried out with the PC-Software 'Device Management' GV-2.

5

5.1 Overview of the Control Elements

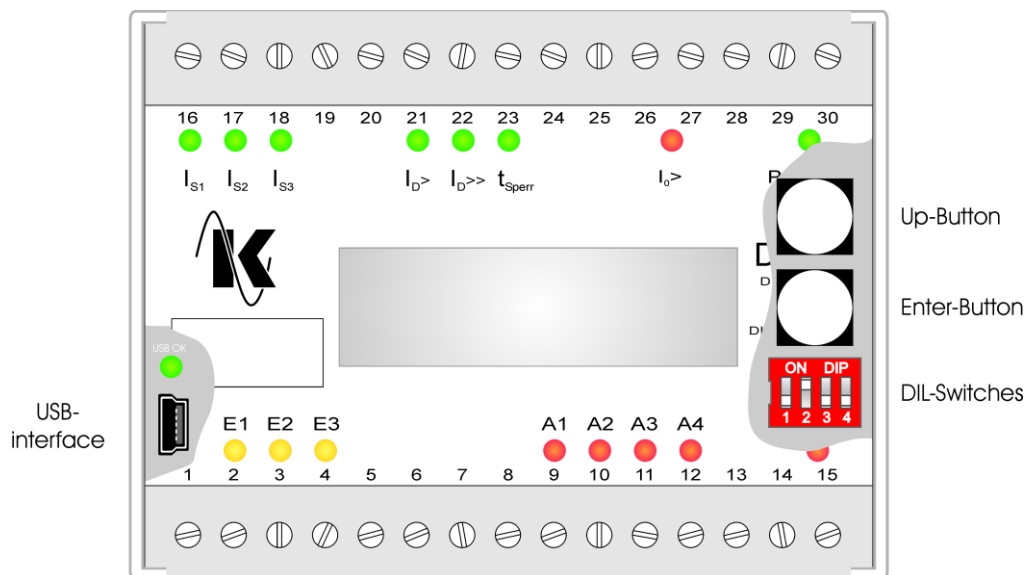

Note: The control elements, DIL switches and communication interface (USB interface) are only accessible, when the front lid of the DSR-8 is removed. It is unconditional to avoid to touch other than the here listed elements. After completion of the intended activities, the cover must be replaced.

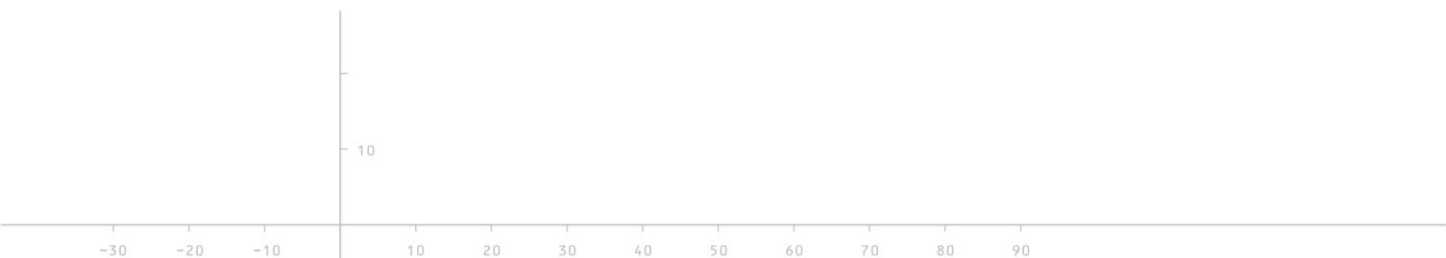

5.1.1 Buttons

For operating of the device, the Differential Current relay DSR-8 has two buttons (*figured below*). In connection with the DIL switch (*see chap. 5.1.2*) and the graphic display almost all relevant settings can be performed directly at the device. The following functions are assigned to the buttons:

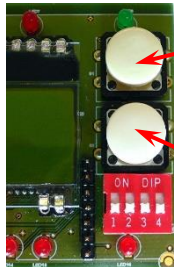

UP Button
(UP)

Enter Button
(ENT)

UP Button

- Scrolling through various menus
- Increasing of a value in the parameter setting (*see chap. 5.2*)
- Deleting of stored trigger values (*see chap. 7.3*)

Enter Button

- Enter a menu item
- Exit a (sub-)menu item (press & hold 2s)
- Confirming an entry
- While operating: switching the display output between absolute & relative values
- In main screen: performing a limit value reset (press & hold 2s, *see chap. 7.1.3*)



Note: The functions of the DSR-8 buttons mentioned above are not to be viewed as a complete list of all functions. Further details and notes on functions of the buttons of the device are described in the respective chapter of this document, which refers to the operation of the device by means of the buttons.

5.1.2 DIL Switches

The DIL Switches have the following functions:

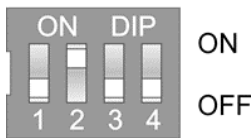

- | | | |
|----------|-----|---|
| S1: | OFF | - automatic fault message reset acc. parameterisation |
| | ON | - STM- auto reset disabled; reset by digital input or reset button (press & hold Enter Button 2s) |
| S2: | ON | - editing of parameters |
| S3: | ON | - change over language |
| S4: | ON | - view / print / delete stored trigger values |
| S2 + S4: | ON | - setting the device clock |

5.1.3 LEDs

The LEDs have the following functions:

- LED E1 ... E3: The LEDs represent the corresponding digital input. If the input is activated (bridged to KI. 1), the associated LED is on (yellow). Hereby the parameterisation of the input after quiescent or working current does not matter.
- LED A1 ... A5: The LEDs represent the corresponding relay output. If the relay output is activated (relay energised), the associated LED is on (red). Hereby the parameterisation of the output after quiescent or working current does not matter.
- LED I_{S1} ... I_{S3}: The LED is on (green), if a sufficient current flow is detected at the respective phase (stabilised current above the detection threshold).
- LED I_{D>} + I_{D>>}: The LEDs are on (red), if the respective stage of the differential current detection triggers (differential current above of the set limit value).
- LED t_{Sperr}: The LED is on (red), if the lock time is set via a parameterised input and has not yet expired.
- LED I_{0>}: The LED is on (red), if an overcurrent limit value of the earth or neutral conductor current measurement is exceeded.
- LED Operation: The LED is on (green), while the DSR-8 is supplied with auxiliary voltage.

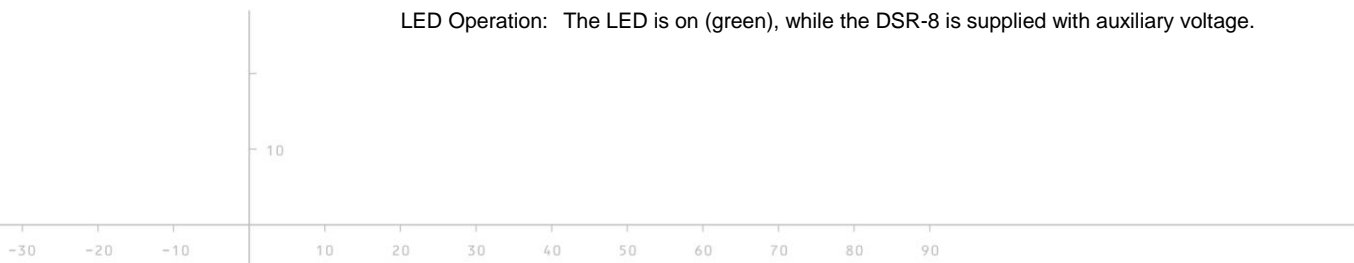



5.1.4 Graphic Display



The device status is output via a backlit graphic display with a resolution of 132 x 32 pixels. In connection with the DIL switches and the Buttons (see chap. 5.1.1) almost all relevant settings can be performed directly at the device. All relevant (measuring-) data are as well shown on the graphic display.

5.1.5 USB Interface / Driver Install



The DSR-8 is equipped with an USB interface (mini-USB), which allows parameterisation of the device. To ensure the correct function, the USB driver file "lpc_driver_setup.exe" must be installed before the first use (file can be found on the delivery included installation medium as well as, after installation of the 'Geräteverwaltung', in the program folder of GV-2). PCs with the operating system Windows 7 or later are supported.

Connect the DSR-8 to the designated PC system using an USB cable (parameterisation cable USB A : USB Mini B - part number: KC0215) and switch on the auxiliary voltage of the DSR-8.

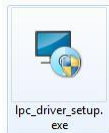

Open the folder 'Treibersoftware' on the installation medium or at the program folder of the parameterisation software 'Geräteverwaltung 2' (GV_2) and start the program 'lpc_driver_setup.exe' (figured left). Follow the installation instructions of the program (enter the administrator password if necessary).

After successful completion of the installation process, the interface 'LPC USB VComPort' should be listed in the Windows device manager (figured right). The parameterisation software 'Geräteverwaltung 2' now can be used with the DSR-8.

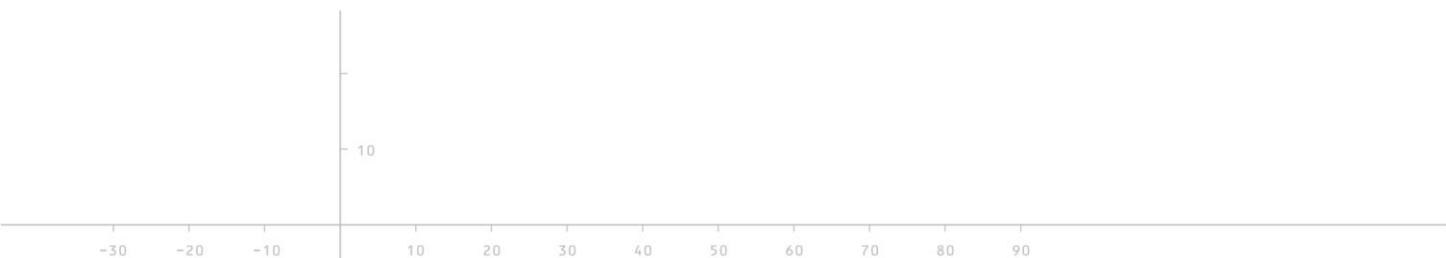



5.2 Display View

5.2.1 Main Screen

The main screen shows all measurements and messages. Using the device configuration, it can be defined whether the stabilised currents or the differential currents of each phase are to be displayed. If the configuration includes a star-delta transformer, or the earth current measurement is parameterised, the measuring value of the neutral- / ground connector will be shown instead of the plant configuration.

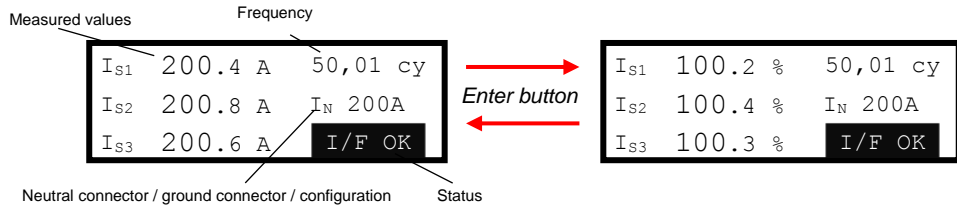

Using the Enter Button the displaying of measuring values can be switched between relative and absolute form. Pressing the UP button, the menu will be entered.

5.2.2 Menu Structure

The menu can be called up from the main screen using the UP button. Pressing the Enter button then activates the respective submenu.

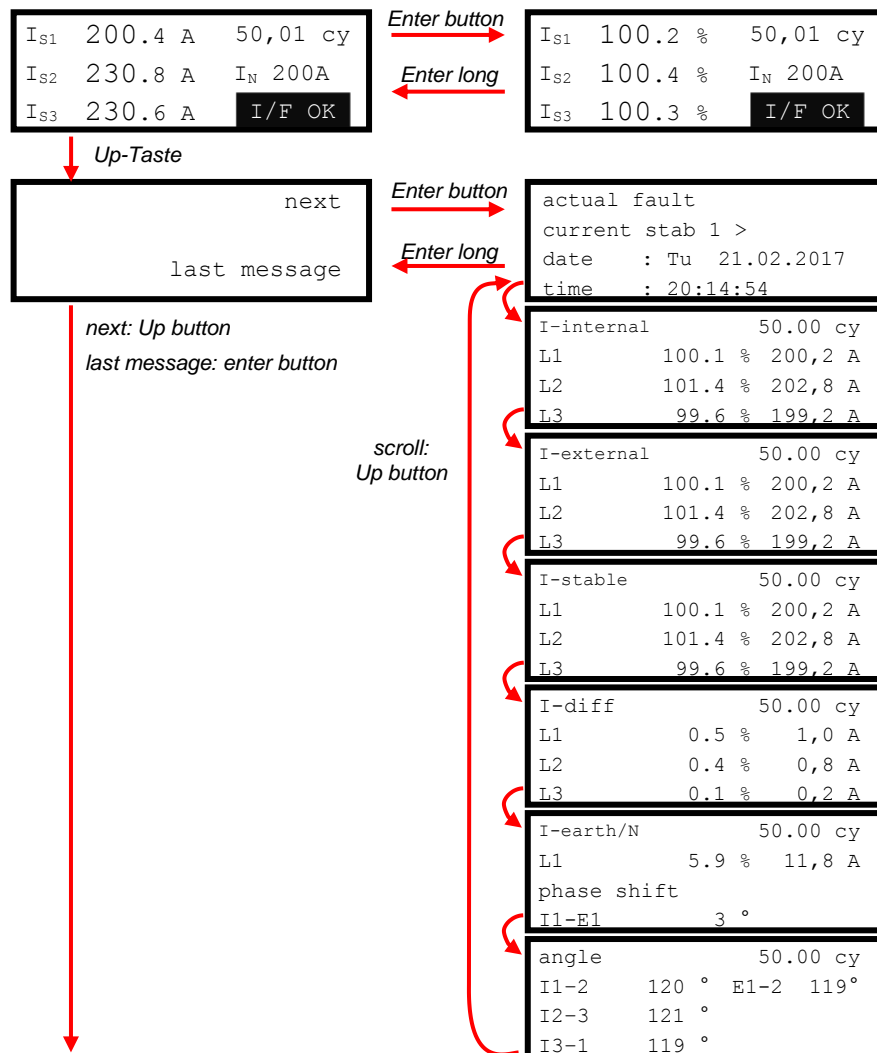

(Onwards on the next page)

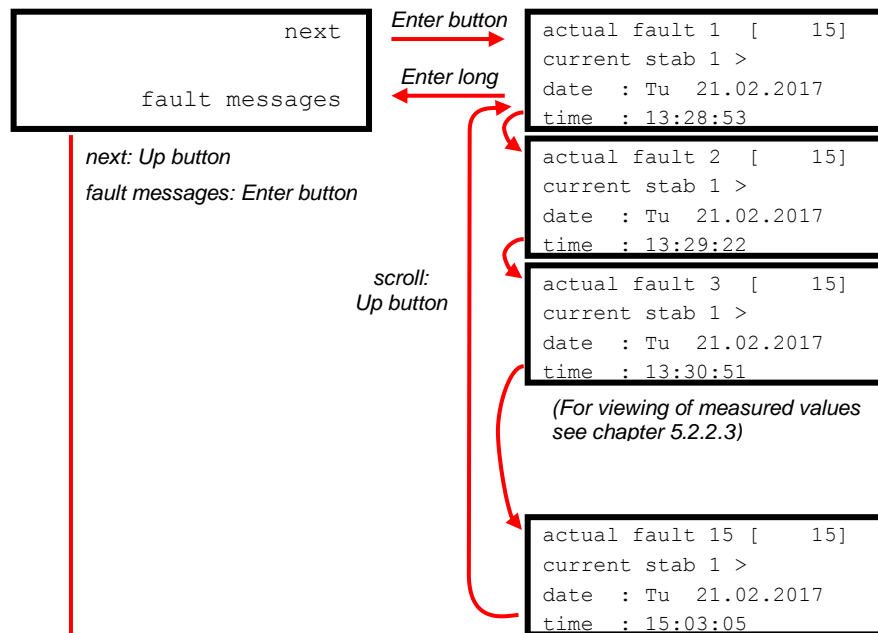
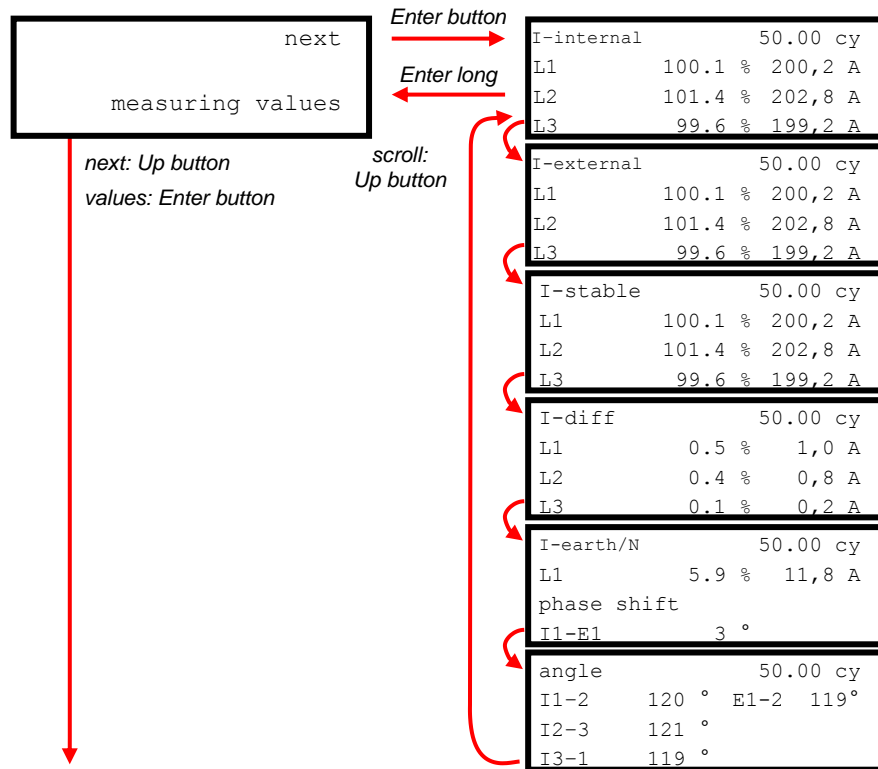

(Onwards on the next page)

10

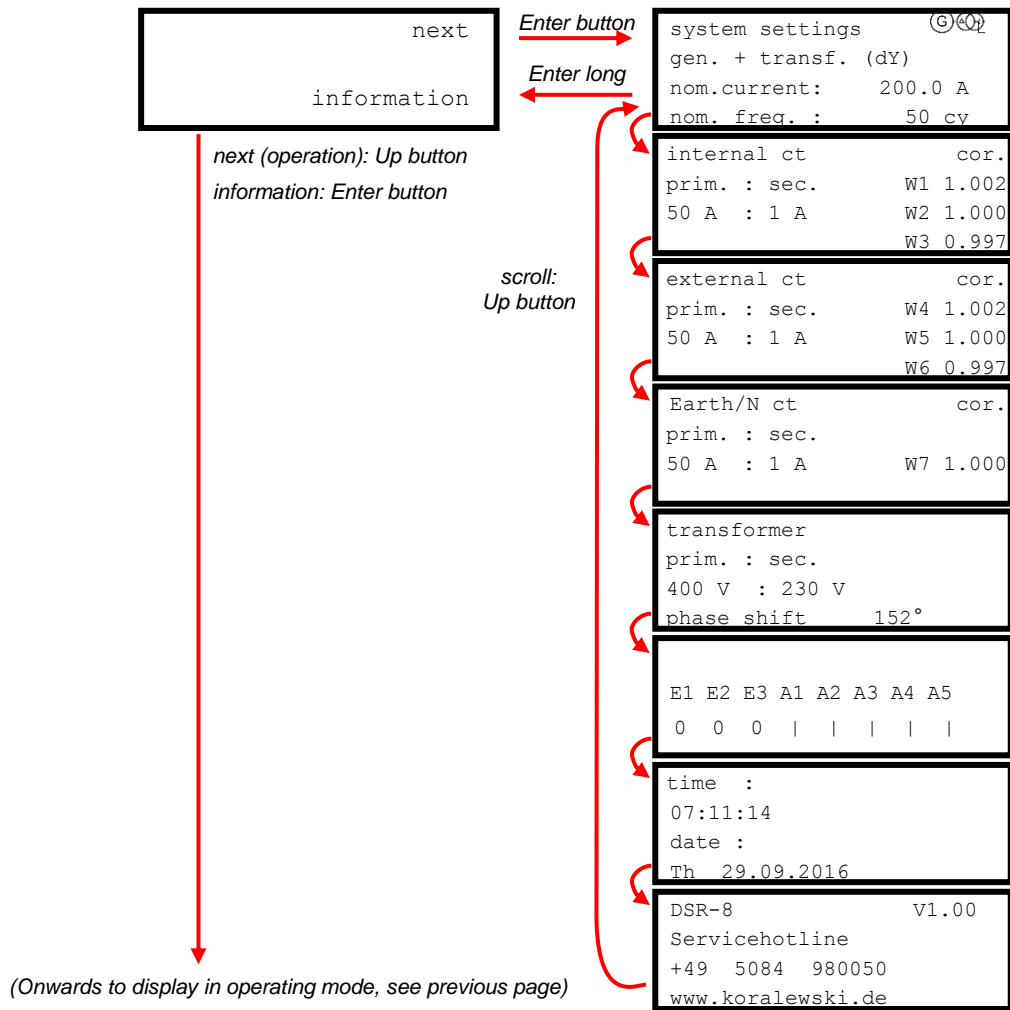



5.2.2.1 Last Message

The last stored message is shown within the menu 'Last Message' – regardless of whether it is still pending. All measuring values available at the time of the message are retrievable. The UP button can be used to scroll through the measuring values listed below. Actuating the Enter button switches back to the selection menu.

- Type and time of the last message
- Internal and external currents of all 3 phases absolute and relative
- Stabilised currents and differential currents of all 3 phases absolute* und relative
- Neutral connector / ground current absolute and relative
- Phase shift between internal and external current
- Phase angle of the individual conductor currents

*(*displaying of absolute values only at plant configurations without transformer)*

5

5.2.2.2 Measuring Values

The current measured values are displayed in the menu 'Measuring Values'. By means of the parameterisation, the display ranges can be pre-selected or can be set as automatic range switching (default setting 0) (see chap. 6).

Scrolling is done using the Up button. Actuating the Enter button switches back to the selection menu.

The following measuring values can be displayed:

- Internal and external currents of all 3 phases absolute and relative
- Stabilised currents and differential currents of all 3 phases absolute* und relative
- Neutral connector / ground current absolute and relative
- Phase shift between internal and external current
- Phase angle of the individual conductor currents

*(*displaying of absolute values only at plant configurations without transformer)*





5.2.2.3 Fault Messages

The 'Fault Messages' menu can be called up via the main menu or by closing of DIL switch 4. In this menu the last 58 on the device stored fault message releases can be displayed. Scrolling through the releases is done with the UP button. Actuating the Enter button changes into the display of individual stored releases. With the Up button one can scroll through the values contained here in. With a long time press (>2s) at the Enter button the display switches back to the previous level.

The following values are retrievable at the point of time of each fault message:

- Type and time of triggering
- Internal and external currents of all 3 phases absolute and relative
- Stabilised currents and differential currents of all 3 phases absolute* und relative
- Neutral connector / ground current absolute and relative
- Phase shift between internal and external current
- Phase angle of the individual conductor currents

(*displaying of absolute values only at plant configurations without transformer)

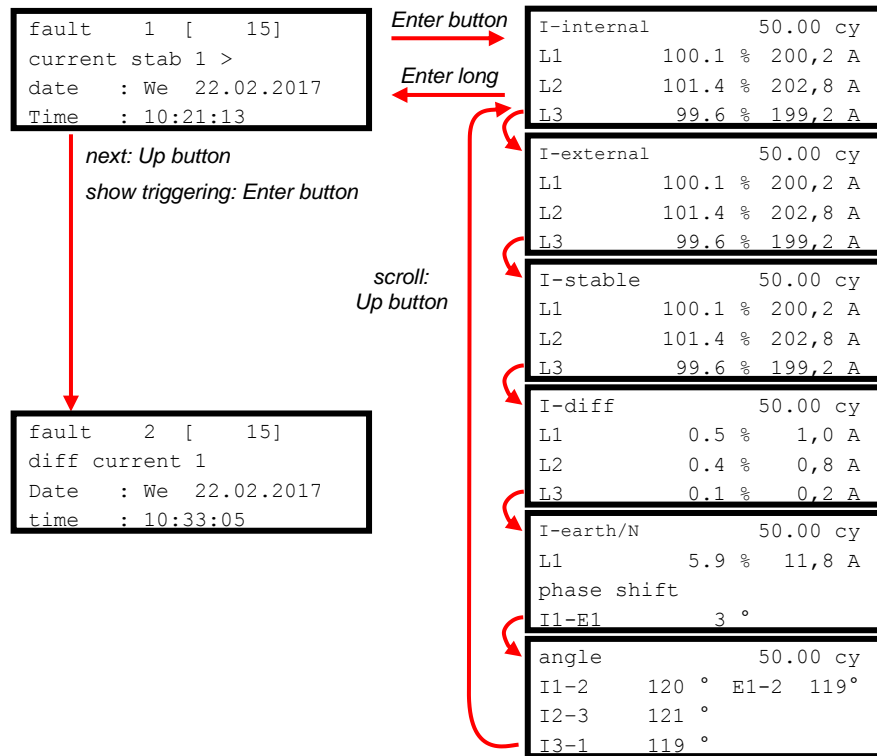

5.2.2.4 Info

Important settings and service information are displayed in the 'Info' menu:

- Type and nominal values of the plant
- Settings of the current transformers
- correction factors of the current transformers
- Setting of transformer (if parameterised)
- Date and time (also setting)
- Firmware- and service information



6 Configuration of the Device

For a correct adjustment to each individual application, the parameterisation of the device is required. For parameterisation the use of the supplied, respectively for downloading on our Homepage www.koralewski.de available parameterisation software 'Geräteverwaltung 2' is recommended. The modification of the most operating settings by direct input at the device is possible as well.

At the first start-up, some settings have to be made in order to adapt the DSR-8 to the respective plant. This includes: nominal voltage, nominal frequency, type of plant and current transformer ratios. If these parameters are not correctly adjusted to the plant, the DSR-8 will not work properly.

6.1 Type of System

The 'Type of System' determines the kind of the protection area for differential current. According to the type of the selected type of system, different parameters may have to be set. The following protection areas are configurable:

No.	Type of System	Transformer*	Ground Current **
0	Generator		X
1	Generator with transformer	X	X
2	Generator with transformer (star-delta)	X	
3	Motor		X
4	Motor with transformer	X	X
5	Motor with transformer (star-delta)	X	
6	Transformer	X	
7	Transformer (star-delta)	X	

* The transmission ratio and the phase rotation of the transformer must be parameterised.

** The seventh current transformer can be used for the detection of a ground current (independent of the differential current protection).

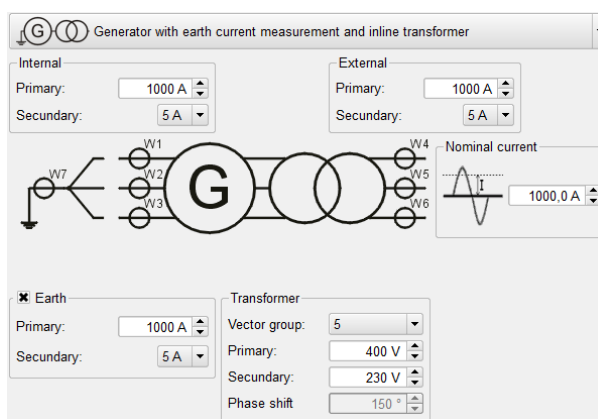

The ratios of the current transformers are edited in the 'Geräteverwaltung' GV_2 (figured above) or directly at the device in the ratio of primary current to secondary current.

If a transformer necessary is to be configured, its primary and secondary voltage as well as its phase rotation must be set for the correct differential current calculation.

If, depending on the configuration, the 7th current transformer is not required for the neutral conductor of a transformer, this can be used, for example, for measuring the earth current at the generator star point.



6.2 Nominal Values of the System

The system nominal values (nominal current, nominal frequency) are also entered via GV_2 or directly at the device.

6.3 Current Transformer Setting

The current transformers required at the plant are divided in three groups: internal converters, external converters and the current transformer for ground- resp. neutral conductor current (figured below).

The primary current can be freely set for each group. Depending on the designated current transformer, the secondary current can be set to 1 A or 5 A.

A correction factor, which enables the calibration to a system, can also be set for each individual current transformer.

6.4 Transformer Setting

If the plant type includes a transformer, for this the voltage ratio and the phase rotation must be parameterised from primary to secondary to ensure a correct differential current forming.

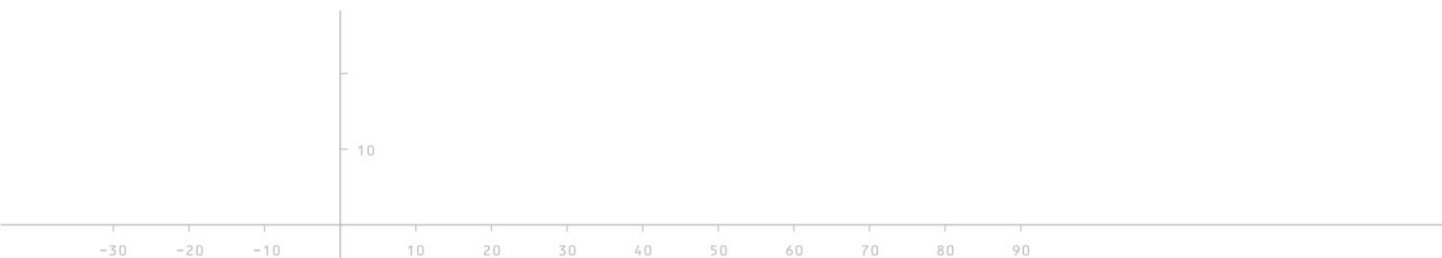



6.5 Measurement Range Selection

The type of output of the current values on the device display is determined by the display format. Factory default setting is 'Automatic' and thus adapts to the selected nominal current of the system. The setting of the display format has no effect on the limit value release.

Number	Selection GV-2	Display format									
0	Automatic										
1	99.9 A	<table border="1"> <tr><td>L1</td><td>10.6 A</td><td>50.01 cy</td></tr> <tr><td>L2</td><td>3.4 A</td><td>Ie 0.06 A</td></tr> <tr><td>L3</td><td>5.6 A</td><td>I/F OK</td></tr> </table>	L1	10.6 A	50.01 cy	L2	3.4 A	Ie 0.06 A	L3	5.6 A	I/F OK
L1	10.6 A	50.01 cy									
L2	3.4 A	Ie 0.06 A									
L3	5.6 A	I/F OK									
2	999 A	<table border="1"> <tr><td>L1</td><td>194 A</td><td>50.01 cy</td></tr> <tr><td>L2</td><td>213 A</td><td>Ie 0.1 A</td></tr> <tr><td>L3</td><td>210 A</td><td>I/F OK</td></tr> </table>	L1	194 A	50.01 cy	L2	213 A	Ie 0.1 A	L3	210 A	I/F OK
L1	194 A	50.01 cy									
L2	213 A	Ie 0.1 A									
L3	210 A	I/F OK									
3	9.99 kA	<table border="1"> <tr><td>L1</td><td>5.60 kA</td><td>50.01 cy</td></tr> <tr><td>L2</td><td>5.61 kA</td><td>Ie 0 A</td></tr> <tr><td>L3</td><td>5.60 kA</td><td>I/F OK</td></tr> </table>	L1	5.60 kA	50.01 cy	L2	5.61 kA	Ie 0 A	L3	5.60 kA	I/F OK
L1	5.60 kA	50.01 cy									
L2	5.61 kA	Ie 0 A									
L3	5.60 kA	I/F OK									
4	99.9 kA	<table border="1"> <tr><td>L1</td><td>56.2 kA</td><td>50.01 cy</td></tr> <tr><td>L2</td><td>56.1 kA</td><td>Ie 0.01kA</td></tr> <tr><td>L3</td><td>56.0 kA</td><td>I/F OK</td></tr> </table>	L1	56.2 kA	50.01 cy	L2	56.1 kA	Ie 0.01kA	L3	56.0 kA	I/F OK
L1	56.2 kA	50.01 cy									
L2	56.1 kA	Ie 0.01kA									
L3	56.0 kA	I/F OK									
5	999 kA	<table border="1"> <tr><td>L1</td><td>62 kV</td><td>50.01 cy</td></tr> <tr><td>L2</td><td>61 kV</td><td>Ie 1.1kA</td></tr> <tr><td>L3</td><td>60 kV</td><td>I/F OK</td></tr> </table>	L1	62 kV	50.01 cy	L2	61 kV	Ie 1.1kA	L3	60 kV	I/F OK
L1	62 kV	50.01 cy									
L2	61 kV	Ie 1.1kA									
L3	60 kV	I/F OK									

The DSR-8 can be parameterised for amperages up to 1000 kA.

6.6 Configuration via GV-2

Values and settings, which are stored on the DSR-8 can be read out at any time from the device with a PC system by means of the parameterisation software 'Geräteverwaltung 2' (GV-2). The data can be stored on the PC and printed out for documentation purposes. For detailed user instructions of 'Geräteverwaltung 2', please refer to the related user manual, available as download on our homepage www.koralewski.de.

6.7 Editing at the Device

The setting of most values is also possible directly at the device. The menu for editing the parameters is called up in operating mode (see chap. 7) - while the main screen is shown in the device display - by closing the DIL switch S2 (see chap. 5.1.2). The procedure for the input at the device is described in detail below. The parameter data listed in the section parameter groups (see chap. Annex 1) must be observed.

6.7.1 Protection of Input with PIN

The editing at the device can be protected by a four-digit user defined PIN. With activated PIN protection, an input at the device is only possible, after entering the correct PIN.

The PIN is entered digit by digit from right to left (see also chap. 6.8.2). Using the UP button the respective digit is incremented, with the Enter button the entry of the number will be confirmed and to cursor moves to the next position. If the last digit of the PIN is entered correctly, the display changes into the 'Parameter Setting' menu (see chap. 6.8). If the PIN is entered incorrectly the input line will be reset to 0000. This procedure can be repeated, starting at the last digit (figured above).

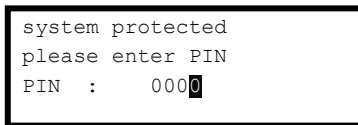

The PIN protection can be set via GV-2 or via the parameter setting at the device (see chap. Annex 1.1) .

Note: After the PIN has been successfully entered, the input protection is automatically activated again, if for longer than 10 minutes no button has been actuated.



6.8 Parameter Setting



If the DIL switch S2 is closed (ON), the device display changes to the parameter setting. To exit the parameterisation, the DIL switch S2 must be opened (OFF) again. If the parameterisation is exited without correctly completing of a begun input, the newly set value gets lost and the previous setting remains active. Set values are stored permanently in the flash module of the device. The values are retained even at loss of the voltage supply, a battery based buffering is not required.

The setting values are arranged in parameter groups (see chap. Annex 1). Each group contains a number of setting values and, where appropriate, further properties. The following groups are available:

- Configuration (Konfig. / Config) Group 1
- Limit values (Grenzwerte / Limits) Group 4
- Digital output (Digital Ausg. / Out) Group 6
- Digital input (Digital Eing. / In) Group 7
- Logic table (Logik) Group 10

6.8.1 Selecting of Groups and Parameters

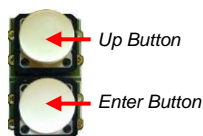

In parameter setting mode (DIL switch S2 closed, input protection PIN inactive) the device display shows the selection of the parameter group (*parameter groups see chap. Annex 1*). Using the Up button (see chap. 5.1.1), the respective parameter group, which is intended to be edited, can be selected.

By actuating the Enter button, the display changes into the menu of the selected group. The subgroup with its parameters to be edited (see chap. Annex 1), can be selected herein by means of the scroll function of the Up button (see chap. 5.1.1). Shown in the example (figured below): Switching from parameter subgroup 6.1.x (Digital Output A1) to 6.2.x (Digital Output A2).

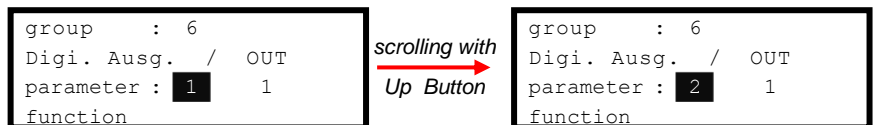

The selected subgroup is now called up with the Enter button. The parameter to be changed can be selected in this menu item using the Up button. Shown in the example (figured below): Switching from parameter 6.2.1 (Function A2) to parameter 6.2.2 (Switching behaviour A2 – refer to chap. 9.1).

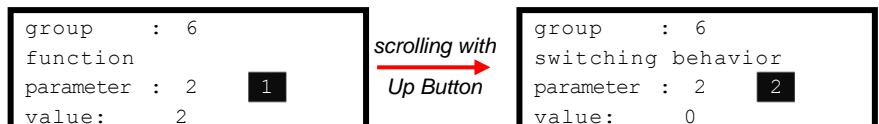

Press the Enter key to call up the menu for the editing of the parameter to be changed. After the entry has been made and the change is confirmed (see chap. 6.8.2), the display returns to the menu of the current parameter subgroup.

To move from one menu level to the next higher, that is from the subgroup to the parameter group and from the parameter group (see chap. Annex 1) to the group selection, the enter key must be pressed for approx. 1.5 seconds (figured below).

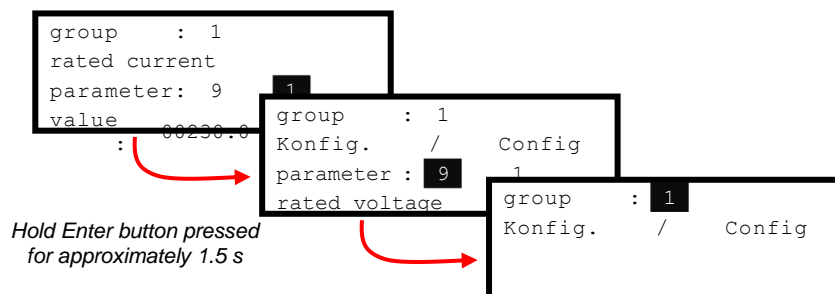



6.8.2 Entering of a Value

After selecting the parameter group and -subgroup, as well as the selection of the parameter value, the editing of the value is initiated by pressing the Enter button again. The cursor is at the last position of the value to be edited (*figured right below*).

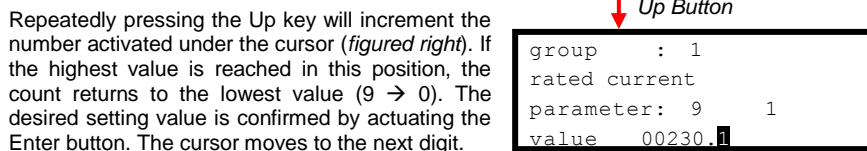

Repeatedly pressing the Up key will increment the number activated under the cursor (*figured right*). If the highest value is reached in this position, the count returns to the lowest value (9 → 0). The desired setting value is confirmed by actuating the Enter button. The cursor moves to the next digit.

This operation is repeated for all digits of the current value to be changed.

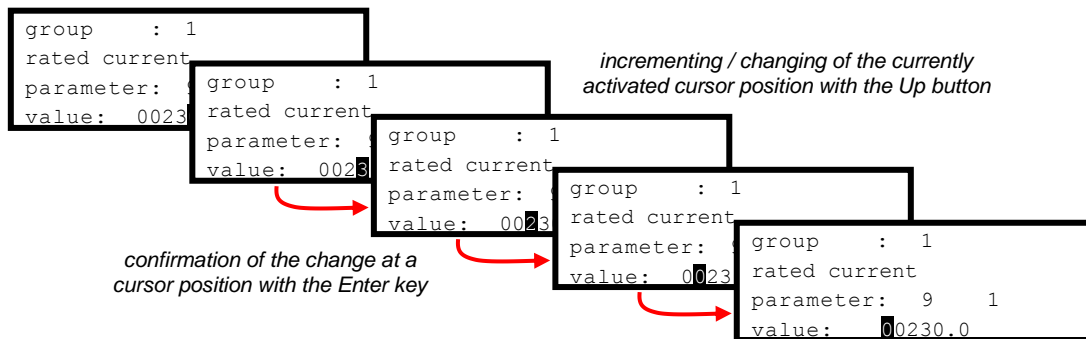

6

When the last digit (the left position) of the value to be changed has been edited and confirmed with the Enter key, a safety query occurs, with which the change of the parameter value must be confirmed. Using the Up button, the current change can be canceled here. The previous setting is retained.

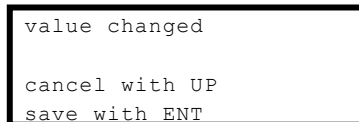

Actuating the Enter button (ENT), the entry of the parameter value is accepted and stored in the flash memory of the DSR-8. The value is valid immediately after confirmation.

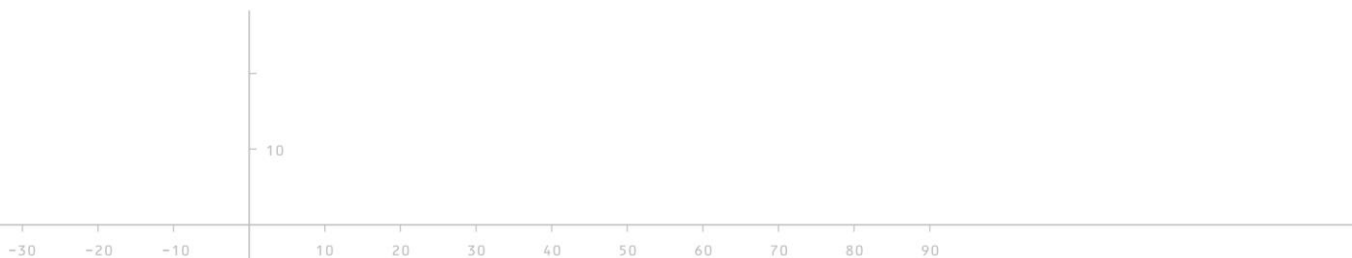



6.8.3 Setting the Fault Message Coding

The setting of the fault message behaviour is performed bit by bit for the respective limit values. With the selection of parameter 6.x.6 (see chap. Annex 1.2) the value in the bottom line of the display is switched to binary number (figured right).

```
Grenzwerte / Limits
low frequency 1
parameter : 1
1000000000001001
```

The bit positions 1, 5, 6, 7, 8, 12, 13, 14, 15 and 16 are adjustable:

```
Grenzwerte / Limits
low frequency 1
enable
1000000000001001
```

Bit position 1 / enable:
The triggering of the fault message for the respective limit value is activated (1) / not activated (0).

```
Grenzwerte / Limits
low frequency 1
disable all
1000100000001001
```

Bit position 5 / disable all (**only Logic Table [10]**):
The respective limit value can be disabled (1) for the triggering by means of the 'disable all' function.

```
Grenzwerte / Limits
low frequency 1
disable 2
1000010000001001
```

Bit position 6 / disable 2:
The respective limit value can be disabled (1) for the triggering by means of the 'disable 2' function.

```
Grenzwerte / Limits
low frequency 1
disable 1
1000000000001001
```

Bit position 7 / disable 1:
The respective limit value can be disabled (1) for the triggering by means of the 'disable 1' function.

```
Grenzwerte / Limits
low frequency 1
Trip lock time
1000000000001001
```

Bit position 8 / Trip lock time:
The respective limit value can be disabled (1) for the triggering by means of an active Lock time.

```
Grenzwerte / Limits
low frequency 1
disable trip lock time
1000000000001001
```

Bit position 12 / disable trip lock time:
The respective limit value resets (1) an active lock time upon triggering (only if supported by the limit value).

```
Grenzwerte / Limits
low frequency 1
automatic reset
1000000000001001
```

Bit position 13 / automatic reset:
The automatic reset (see chap. 7.1.3) is enabled (1) / disabled (0) for the respective limit value.

```
Grenzwerte / Limits
low frequency 1
central fault 2
1000000000001001
```

Bit position 14 / central fault 2:
The fault message triggering for the limit value is additionally - not (0) / carried out (1) under 'central fault 2' (see chap. 7.1.6).

```
Grenzwerte / Limits
low frequency 1
central fault 1
1000000000001001
```

Bit position 15 / central fault 1:
The fault message triggering for the limit value is additionally - not (0) / carried out (1) under 'central fault 1' (see chap. 7.1.6).

```
Grenzwerte / Limits
Unterfrequenz 1
central fault
1000000000001000
```

Bit position 16 / central fault:
(only Logic Table [10]):
The fault message triggering for the limit value is - not (0) / carried out (0) under 'central fault' (see chap. 7.1.6).

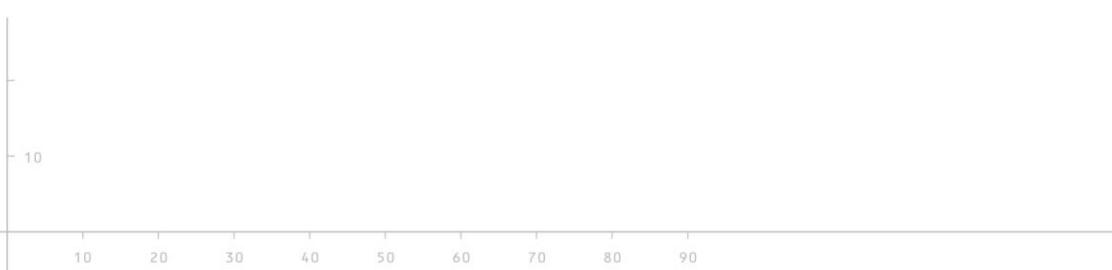



6.9 Setting of Time and Date

The real-time clock integrated in the DSR-8 operates in 24h format and continues to run for at least 72 hours in case of auxiliary power supply fails. Date and time of the DSR-8 can be adjusted in different ways.

1. Using the parameterisation software GV_2.
2. Manually at the device.

6.9.1 Via GV-2

Time and date are adjustable via GV-2. On this, the time of the used PC system is applied.

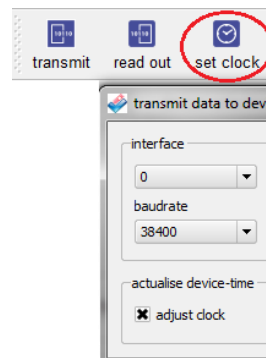

The clock of the DSR-8 can be set by clicking on 'set clock', or while transferring or reading out the configuration. For this, the option 'adjust clock' must be activated during transmission.

6

6.9.2 Manually Setting of the Time

The setting of date and time is called up at the device by closing of the DIL switches S2 and S4. Actuating the Enter button, the editing is activated.



Using the Up button (see chap. 5.1.1), now the activated digit is altered. The made setting is confirmed by actuating the Enter button, the cursor changes to the next position of the input area (figured below – refer chap. 6.8.2).

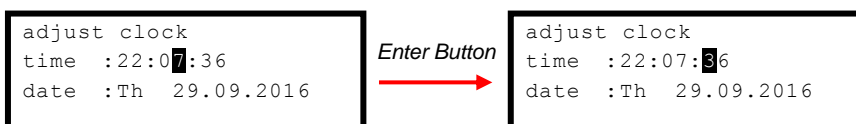
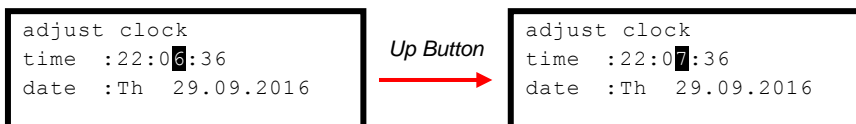

The procedure described above must be repeated for all positions of the time and date input.



Note: The day of the week can not be set manually. The day of the week is set automatically on the base of the set date.

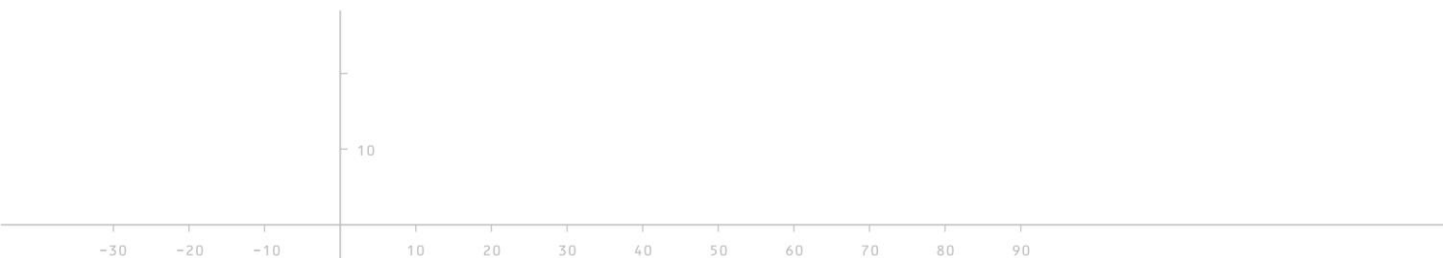



6.10 Language Selection and -Switching

Basically the display texts are available at the device in 2 languages. The factory default is German and English. Other languages can be set up at the customer's request and thus made available on the device display by means of the parameterisation software.

```
Wert wurde geändert
Abbruch mit UP
Speichern mit ENT
```

```
value changed
cancel with UP
save with ENT
```

Using the device parameterisation it is determined which language is the main language, and whether it is allowed to switch between the languages. The following options are adjustable:

- only language 1 (German)
- only language 2 (English)
- language 1 or language 2 (German / English)
- language 2 or language 1 (English / German)

The switching between the two display languages can alternatively be carried out via the parameterisation software, DIL switch S3 or a parameterised input. If DIL switch S3 or the assigned input is closed, the language is switched according to the parameterization, if the changeover is permitted.

7 Operation

7

In the operation mode, the DSR-8 displays current measured values. Depending on the parameterisation, the stabilised currents or the differential currents are shown, alternatively as absolute or relative values.

Measurement values

I _{S1}	200 A	50,01 cy	Frequency
I _{S2}	200 A	⊕ ⊖ 200A	Type of system / nominal current
I _{S3}	200 A	I / F OK	Fault message

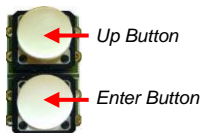

Using the Enter button, the displaying at the device can be switched between absolute and relative values. The menu is called up with the Up-button. After an adjustable view reset time, the display of the DSR-8 turns back from the sub menus to the main screen. The view reset time itself is reset with each keystroke. If the view reset time is adjusted at 0 s, the display remains within the actually shown menu, up to the next. In the following, the main menu level is shown.

7.1 Limit Values

7.1.1 Behaviour of the Limit Values

All limit values can be adjusted and assigned to a relay separately. A set and active limit value is displayed as a triggering message in the display, regardless of whether the limit value has been laid to a relay or to one of the fault messages. Each limit value message leads to the activation of the internal collective fault message and can optionally be linked to the freely configurable collective messages.

7.1.2 Tripping of Limit Values

The tripping is basically carried out when the respective measured value exceeds or falls short of the set limit value and the set delay time has elapsed. Each trigger value has its own delay time. The delay times are individually adjustable for each limit value in the range from 0.05 s to 999.9 s.

Switching back after a limit value tripping occurs when the respective measured value has again fallen below or exceeded the set limit value plus hysteresis.

The message duration can be set between 0.1 s and 6000.0 s for each relay in the configuration of the outputs. The set value causes the corresponding relay contact to remain accessed at least for the set time, even if the exceeding or shortfall of the limit value is of shorter duration.





7.1.3 Manually / Automatically Reset

Ex factory all limit values are set to automatic reset. This automatic reset can be disabled for each individual limit value. If the autoreset is activated, the reset is carried out automatically as soon as the triggering condition no longer exists.

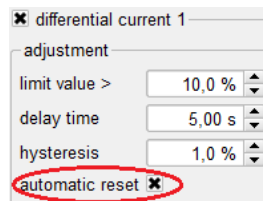

Limits for which the automatic reset is deactivated can only be reset by means of a correspondingly configured digital input (see chap. 8.1) or with the reset function of the Enter button (long actuating of the Enter button while the main screen is shown at the device display). The manual reset works edge-controlled and resets all limit messages for 1 s. If limit value messages are still pending, they are again indicated with the end of the reset time.



Note: The automatic reset is basically deactivated for all parameterised limit value messages by closing the DIL switch S1 (ON).



Note: Resetting the fault messages by means of the Enter key (hold pressed for 2 s) is only possible while the main screen is displayed.

7.1.4 Locking of Trippings

Individual or all limit value messages can be deactivated by means of the parameterisable digital inputs (see chap. 8.1). Up to 3 locking functions can be assigned to each limit value. The global lock function 'disable all' always deactivates all active limit messages. If the input is set, the corresponding limit value messages are suppressed. The following lock functions are available:

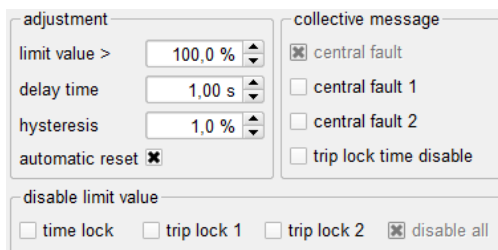

7

- disable all (Standard E1)
- time lock
- trip lock 1
- trip lock 2

7.1.5 Locking Time

Limit value trippings can be suppressed for an adjustable period of time by means of the 'locking time' function. By activating of an input, which is parameterised with a locking time, the temporary blocking begins, which means that the triggering for limit values, which have been accordingly parameterised is prevented until the time has elapsed. If the input is newly set again, the complete locking time will run down again. The locking time lock is fixed preset for the triggering of 'differential current 1' and 'differential current 2', for the other limit values it can be set under the locking functions. It is used, for example, to prevent fault triggerings while switching on the plant.

Optionally the locking time can be reset by means of overcurrent limits. For this, the global option 'force trip in case of overcurrent', and for the limit value 'Lock time suppression' must be set.

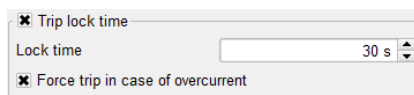

7.1.6 Central fault

All limit value messages are entered into the central collective fault signal if the limit value message is activated, the limit value is exceeded respective fallen short of and the delay time has elapsed.

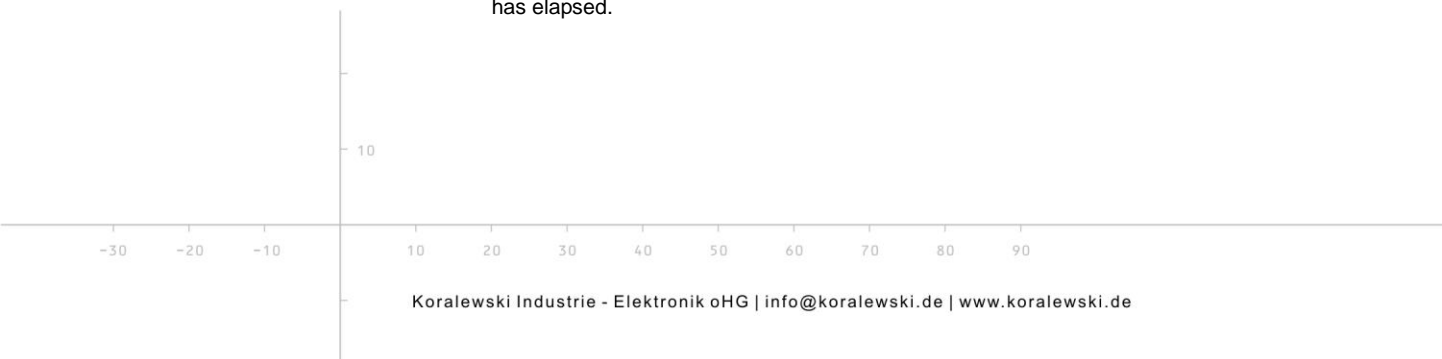



7.1.7 Central fault 1+2

The device offers the possibility to form two independent collective fault signals. These are composed of the individual limit values. The operator thus can configure a specific event himself.

By activating the corresponding assignment, each adjustable limit value can be added to the 'central fault 1' and/or 'central fault 2'.

Example:

- Limit value setting: at differential current 1, under-frequency 2 und over-frequency 1 Central fault 1
- Setting digital outputs: function relay 5: 3 = Central fault 1

This combination of the settings causes the relay 5 to be energised when at least one of the 3 limit value events occurs.

7.1.8 Display First Fault

By means of parameterisation, the device can be specified to as whether there should only be a first value triggering (first fault), or also the triggering of subsequent faults. 'Display first fault only' means, that e.g. in the case of a non-delayed triggering of the higher limit value 'overcurrent 2', a triggering of the lower limit value 'overcurrent 1', which due to a parameterised delay inevitably occurs later, no longer is evaluated. If 'display first fault only' is deactivated, all the triggerings are displayed and stored in the internal fault memory in the order of occurrence.



7.2 Limit Value Setting

Each limit value can be set individually and is shown below: percentagewise adjustable limit values always refer to the respective configured nominal value.

7.2.1 Rotary Field Protection

Function	Range	Hysteresis	Delay time	Tolerance
Protection of rotary field	left / right	10°	0.5 s	+/-1.0° -0,01 / +0.02 s

The respective smallest or largest of the three phase angles is used as the trigger criterion for the rotary field protection. If it exceeds- or falls below 180 °, the signal 'rotary field fault' is generated and output. Thereby the DSR-8 differentiates according to the internal and external rotary field, in order to detect any faults in the wiring. The rotary field fault has no effect on the other fault signals. The monitoring can be adjusted on left or right rotary field by the parameterisation software. To the factory setting, the rotary field protection of the DSR-8 is not activated.



Note: The rotary field protection, hysteresis and delay time are fixed preset and can not be adjusted.

7.2.2 Differential Current Tripping

Function	Range	Hysteresis	Delay time	Tolerance
Differential current 1	1.0 ... 199.9 %	0.5 ... 50.0 %	0.05 s ... 999.99 s	+/-0.1 % -0.01 / +0.02 s
Differential current 2	1.0 ... 199.9 %	0.5 ... 50.0 %	0.05 s ... 999.99 s	+/-0.1 % -0.01 / +0.02 s

Two different limit values can be set for the differential current tripping. Each limit value has its own tripping delay. The differential current is tripped by means of an adjustable characteristic curve. If the stabilised current of one phase exceeds the break point, the limit value for the differential current increases with the set slope in proportion to the super elevation.

10

-30 -20 -10

10 20 30 40 50 60 70 80 90

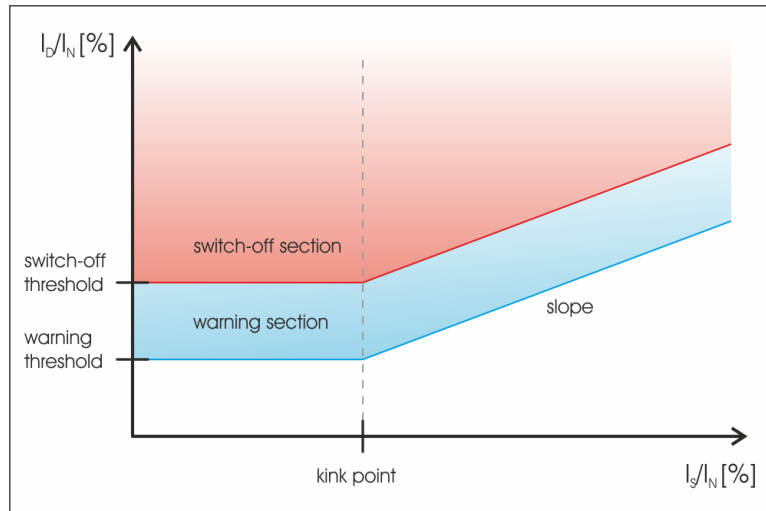

Example:

Differential Current 1		
Limit value	20 %	The stabilised current of the phase amounts to 200 %. If the differential current of this phase exceeds 20.0%, the signal 'differential current 1' is set after 0.08 s.
Delay time	0.08 s	
Hysteresis	0.5 %	
Break point	200 %	The switching back takes place as soon as the differential current has fallen below the value of 29.5%.
Slope	10 %	

7

7.2.3 Overcurrent Tripping, stabilised Current

Function	Range	Hysteresis	Delay time	Tolerance
Overcurrent (stabilised) 1	10.0 ... 399.9 %	0.5 ... 50.0 %	0.05 s ... 999.99 s +/- 0.1 %	-0.01 / +0.02 s
Overcurrent (stabilised) 2	10.0 ... 399.9 %	0.5 ... 50.0 %	0.05 s ... 999.99 s +/- 0.1 %	-0.01 / +0.02 s

Two different limit values can be set for the overcurrent release. Each limit value has its own tripping delay.

Example:

Overcurrent (stabilised) 1		
Limit value	110 %	If the average value of the current of one phase exceeds 110.0% (220 A at 200 A nominal current), the 'overcurrent 1 (stabilised)' signal is set after 0.08 s.
Delay time	0.08 s	
Hysteresis	0.5 %	Switching back occurs as soon as all phase mean values have fallen below the value of 109.5% (219 A).

7.2.4 Overcurrent Tripping, internal Current

Function	Range	Hysteresis	Delay time	Tolerance
Overcurrent (internal) 1	10.0 ... 399.9 %	0.5 ... 50.0 %	0.05 s ... 999.99 s +/- 0.1 %	-0.01 / +0.02 s
Overcurrent (internal) 2	10.0 ... 399.9 %	0.5 ... 50.0 %	0.05 s ... 999.99 s +/- 0.1 %	-0.01 / +0.02 s

Two different limit values can be set for the overcurrent release. Each limit value has its own tripping delay.

Example:

10



Overcurrent (internal) 1		
Limit value	110 %	If the internal current of one phase exceeds 110.0% (220 A at 200 A nominal current), the 'overcurrent 1 (internal)' signal is set after 0.08 s.
Delay time	0.08 s	Switching back (reset) occurs as soon as all internal currents have fallen below the value of 109.5% (219 A).
Hysteresis	0.5 %	

7.2.5 Overcurrent Tripping external Current

Function	Range	Hysteresis	Delay time	Tolerance
Overcurrent (external) 1	10.0 ... 399.9 %	0.5 ... 50.0 %	0.05 s ... 999.99 s	+/- 0.1 % -0.01 / +0.02 s
Overcurrent (external) 2	10.0 ... 399.9 %	0.5 ... 50.0 %	0.05 s ... 999.99 s	+/- 0.1 % -0.01 / +0.02 s

Two different limit values can be set for the overcurrent release. Each limit value has its own tripping delay.

Example:

Overcurrent (external) 1		
Limit value	110 %	If the external current of one phase exceeds 110.0% (220 A at 200 A nominal current), the 'overcurrent 1 (external)' signal is set after 0.08 s.
Delay time	0.08 s	Switching back occurs as soon as all external currents have fallen below the value of 109.5% (219 A).
Hysteresis	0.5 %	

7

7.2.6 Overcurrent Tripping, Earth- / Neutral Conductor Current

Function	Range	Hysteresis	Delay time	Tolerance
Overcurrent (Earth/N) 1	10.0 ... 399.9 %	0.5 ... 50.0 %	0.05 s ... 999.99 s	+/- 0.1 % -0.01 / +0.02 s
Overcurrent (Earth/N) 2	10.0 ... 399.9 %	0.5 ... 50.0 %	0.05 s ... 999.99 s	+/- 0.1 % -0.01 / +0.02 s

Two different limit values can be set for the overcurrent release. Each limit value has its own tripping delay.

Example:

Overcurrent (Earth/N) 1		
Limit value	10 %	If the earth- or neutral conductor current exceeds 10.0% (20 A at a nominal current of 200 A), the 'overcurrent 1 (Earth / N)' signal is set after 0.08 s.
Delay time	0.08 s	The switching back takes place as soon as all external currents have fallen below the value of 9.5% (19 A).
Hysteresis	0.5 %	

7.2.7 Overcurrent Time Protection

Function	Range	Time multiplier	Tolerance
Thermal monitoring	• IEC normal inverse	0,05 s ... 15.0	+/- 0.1 % -0.01 / +0.02 s
	• IEC very inverse		
	• IEC extremely inverse		
	• IEC long time inverse		
	• ANSI inverse		
	• ANSI short inverse		
	• ANSI long inverse		
	• ANSI moderately inverse		
	• ANSI very inverse		
	• ANSI extremely inverse		
	• ANSI definite inverse		





Various characteristics (see Annex 2 - Overcurrent-Time-Protection Curves) and time multipliers can be selected for thermal overcurrent tripping. If the current exceeds the value set according to the characteristic curve and time, the 'overcurrent thermally' signal is set.

Example:

Thermal monitoring	Time multiplier
IEC normal inverse	0,2

If I = 200 % triggering takes place after 2.0 s.
The switching back takes place as soon as the current has fallen below of the limit value.

7.2.8 Tripping of Frequency

Function	Range	Hysteresis	Delay time	Tolerance
Underfrequency 1	35.00 ... 65.00 cy	0.05 ... 2.00 cy	0.05 s ... 999.99 s	+/-0.01 cy -0.01 / +0.02 s
Overfrequency 1	35.00 ... 65.00 cy	0.05 ... 2.00 cy	0.05 s ... 999.99 s	+/-0.01 cy -0.01 / +0.02 s
Underfrequency 2	35.00 ... 65.00 cy	0.05 ... 2.00 cy	0.05 s ... 999.99 s	+/-0.01 cy -0.01 / +0.02 s
Overfrequency 2	35.00 ... 65.00 cy	0.05 ... 2.00 cy	0.05 s ... 999.99 s	+/-0.01 cy -0.01 / +0.02 s

Frequency tripping is generally carried out on phase L1 internally. For the under- and overfrequency detection respectively two different limit values can be set. Each limit has its own tripping delay.

Example:

Overfrequency 1	
Limit value	51.20 cy
Delay time	0.08 s
Hysteresis	0.10 cy

If the measured frequency exceeds 51.20 cy, the 'Overfrequency 1' signal is set after 0.08 s. The reset occurs as soon as the frequency falls below 51.10 cy.

7.3 Tripping Memory

The DSR-8 stores the measured values for the respective limit value trippings. The fault memory can store the values of up to 52 tripping events. The tripping values are permanently stored in the flash memory of the device with the date and time and are retained even in case of loss of the auxiliary voltage. The number of detected trippings is stored in a counter (maximum 65,000, can not be erased, reset to 0 if exceeded). The tripping values can be read on the device.

The output of the trippings on the device's graphic display is called up by closing the DIL switch S4 (see chap. 5.1.2) while in the operation mode the main screen is displayed. First, the last tripping is shown. Actuating the UP button (for the function of the buttons see chap. 5.1.1), the different values of the triggering can be viewed. Using the Enter button, one can scroll backwards through the stored trippings. When the oldest stored tripping is reached, the display returns back to the most recently stored tripping.

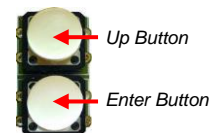

The stored tripping values are cleared by holding pressed down the UP button for approx. 10 seconds while the DIL switch S4 is closed (display output figured right). Then all previously stored tripping values, but not the counter reading for all trippings (refer above), are erased.

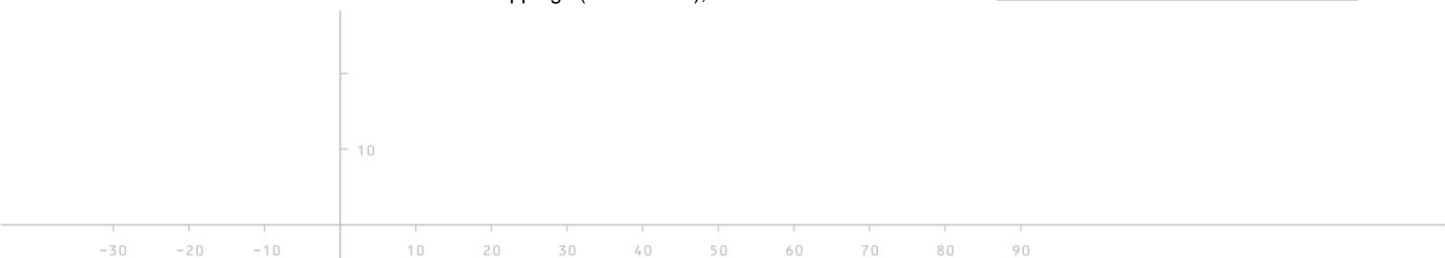
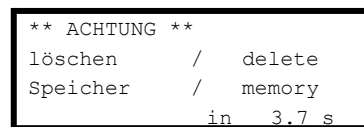



7.3.1 Reading out the Tripping Memory

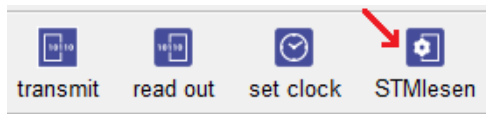

The tripping memory of the DSR-8 can be read out with the parameterisation software GV-2 by clicking the corresponding button (figured left). In the window that appears thereupon, all stored fault messages are listed chronologically. The fault messages can be stored as plain text file (*.txt) on the PC system.

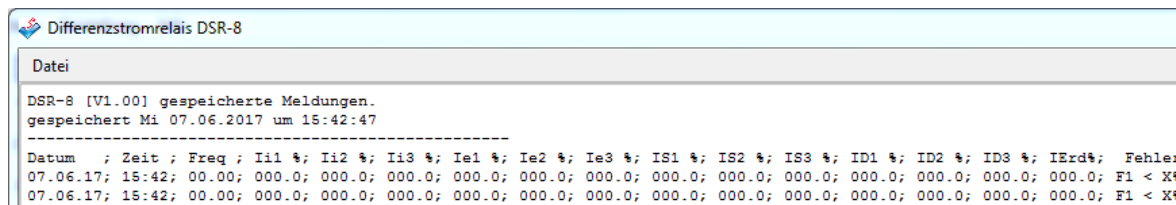

7.4 Programmable Switching Points

In addition to the adjustable limit values, the DSR-8 has 3 programmable switching points. Each switching point can be assigned to a selection of functions. Hereby switching behaviour, hysteresis and a deceleration time can be set. The following values are available:

No.	Function	Description
0	deactivated	Output is not active.
1	I_{D1}	Differential current L1 scaled in xx.x % of the nominal current.
2	I_{D2}	Differential current L2 scaled in xx.x % of the nominal current.
3	I_{D3}	Differential current L3 scaled in xx.x % of the nominal current.
4	$(I_{D1}+I_{D2}+I_{D3})/3$	Average of differential current in xx.x % of the nominal current.
5	I_{S1}	Stabilised current L1 scaled in xx.x % of the nominal current.
6	I_{S2}	Stabilised current L2 scaled in xx.x % of the nominal current.
7	I_{S3}	Stabilised current L3 scaled in xx.x % of the nominal current.
8	$(I_{S1}+I_{S2}+I_{S3})/3$	Average of the stabilised current in xx.x % of nominal current.
9	$I_{Intern1}$	Internal current L1 scaled in xx.x % of the nominal current.
10	$I_{Intern2}$	Internal current L2 scaled in xx.x % of the nominal current.
11	$I_{Intern3}$	Internal current L3 scaled in xx.x % of the nominal current.
12	$(I_{Intern1}+I_{Intern2}+I_{Intern3})/3$	Average of the internal current in xx.x % of the nominal current.
13	$I_{Extern1}$	External current L1 scaled in xx.x % of the nominal current.
14	$I_{Extern2}$	External current L2 scaled in xx.x % of the nominal current.
15	$I_{Extern3}$	External current L3 scaled in xx.x % of the nominal current.
16	$(I_{Extern1}+I_{Extern2}+I_{Extern3})/3$	Average of the external current in xx.x % of the nominal current.
17	$I_{E\text{-arth/N}}$	Earth- / neutral connector current scaled in xx.x % of the nominal current.
18	F_{L1}	Frequency L1 internal scaled in xx.xx cy.

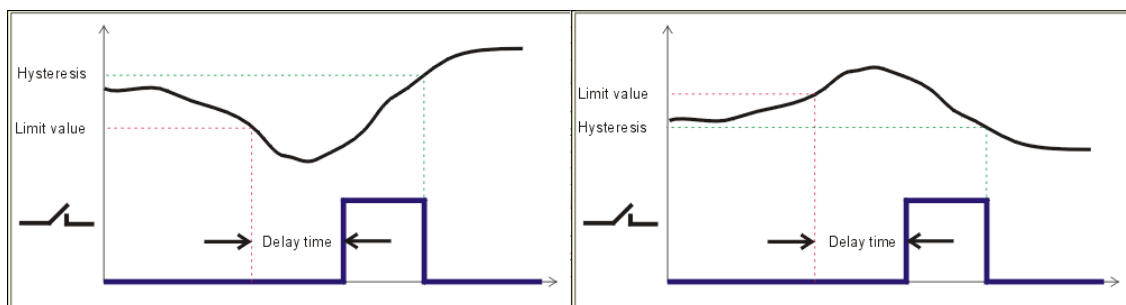



Each switching point can be assigned to a relay output (see chap. 9.1 - Digital Outputs). The output relay then switches according to the parameterisation when the respective measured value is exceeded or undershot. No messages are displayed.



Note: Switching points are NOT considered in the fault message processing!

8 Inputs

8.1 Digital Inputs

The DSR-8 features 3 digital inputs, which can be assigned to one of the following functions:

No.	Function	Description
0	deactivated	Input is not active. Allocation of an output with the terminal of this input is however possible.
1	global disable	All limit value messages are suppressed as long as the input is active.
2	lock time set (pos. edge)	An activation of the input starts the locking time of the device. The differential current triggering and all limit messages, which are parameterised with the locking time, are suppressed until the parameterised locking time has elapsed. Another activation before expiry sets the locking time again.
3	lock time set (pos./neg. edge)	A status change of the input starts the blocking time of the device. The differential current triggering and all limit messages, which are parameterised with the locking time, are suppressed until the parameterised blocking time has elapsed. A once more activation before expiry sets the locking time anew.
4	disable 1	All limit value messages, which are parameterised with disable 1 are suppressed as long as the input is active.
5	disable 2	All limit value messages, which are parameterised with disable 2 are suppressed as long as the input is active.
6	fault reset	Reset of limit value messages, which are not set to 'automatic reset'.
7	change language	Changing of the display language depending on the parameter setting. The language switching can be deactivated.
8	feedback A1 REL1 – KL32	Monitoring of the feedback of the contactor connected to A1. In the event of a fault, the 'collective fault' signal is set after 0.5 s (see chap. 8.1.1 Monitoring of the Relay- (Contactor-) feedback).
9	feedback A2 REL2 – KL33	Monitoring of the feedback of the contactor connected to A2. In the event of a fault, the 'collective fault' signal is set after 0.5 s (see chap. 8.1.1 Monitoring of the Relay- (Contactor-) feedback).
10	feedback A3 REL3 – KL34	Monitoring of the feedback of the contactor connected to A3. In the event of a fault, the 'collective fault' signal is set after 0.5 s (see chap. 8.1.1 Monitoring of the Relay- (Contactor-) feedback).
11	feedback A4 REL4 – KL35	Monitoring of the feedback of the contactor connected to A4. In the event of a fault, the 'collective fault' signal is set after 0.5 s (see chap. 8.1.1 Monitoring of the Relay- (Contactor-) feedback).
12	feedback A5 REL5 – KL37/38/39	Monitoring of the feedback of the contactor connected to A5. In the event of a fault, the 'collective fault' signal is set after 0.5 s (see chap. 8.1.1 Monitoring of the Relay- (Contactor-) feedback).

8

8.1.1 Monitoring of the Relay- (Contactor-) Feedback

If a digital input is assigned with the feedback function, the corresponding message and the collective message are set after 0.5 s, if the feedback contact of the corresponding relay does not correspond to the state of the relay.

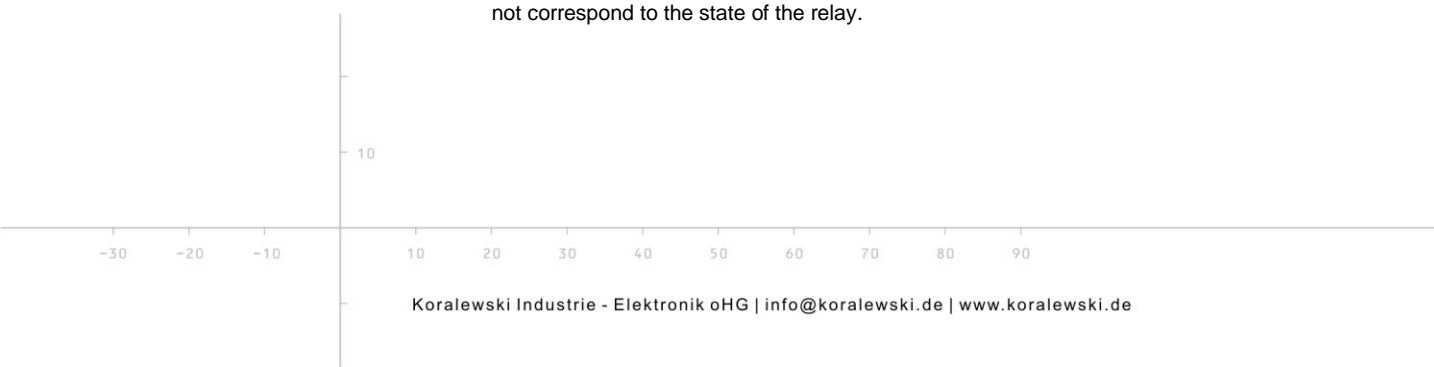



9 Outputs

9.1 Digital Outputs

The DSR-8 features 2 groups of digital outputs (A1 - A4 and A5) with in total 5 relays, which can be assigned to one of the functions of the selection described in the following. For each output relay, a minimum pulse duration within the range from 0.1 s up to 6000 s is adjustable. 'Minimum pulse duration' means, that the corresponding relay remains energised for at least the set time, even if the event which led to the tripping is of a shorter duration. If the event is longer than the set time, the relay de-energises without delay.

No.	Function	Description
0	deactivated	The output is deactivated. If the output is parameterised as per closed circuit principle, the relay is permanently energised.
1	operational	The corresponding relay is energised, when the DSR-8 is ready for operation.
2	central fault	The corresponding relay is energised, when the 'collective fault' is set.
3	central fault 1	The corresponding relay is energised, when the 'collective fault 1' is set.
4	central fault 2	The corresponding relay is energised, when the 'collective fault 2' is set.
5	fault rotary field (Monitoring of rotary field)	The corresponding output relay is activated if the rotary field contacted with the system does not match the parameterised (right or left) rotary field (see chap. 7.2.1).
6	differential current 1 (Current triggering)	The corresponding output relay is activated, when the limit value characteristic line 'differential current 1' is undershot and the delay time has elapsed (see chap. 7.2.2).
7	differential current 2 (Current triggering)	The corresponding output relay is activated, when the limit value characteristic line 'differential current 2' is undershot and the delay time has elapsed (see chap. 7.2.2).
8	overcurrent (stabilised) 1 (Current triggering)	The corresponding output relay is activated when the limit value 'overcurrent (stabilised) 1' has exceeded and the delay time has elapsed (see chap. 7.2.3).
9	overcurrent (stabilised) 2 (Current triggering)	The corresponding output relay is activated when the limit value 'overcurrent (stabilised) 2' has exceeded and the delay time has elapsed (see chap. 7.2.3).
10	overcurrent (internal) 1 (Current triggering)	The corresponding output relay is activated when the limit value 'overcurrent (internal) 1' has exceeded and the delay time has elapsed (see chap. 7.2.4).
11	overcurrent (internal) 2 (Current triggering)	The corresponding output relay is activated when the limit value 'overcurrent (internal) 2' has exceeded and the delay time has elapsed (see chap. 7.2.4).
12	overcurrent (external) 1 (Current triggering)	The corresponding output relay is activated when the limit value 'overcurrent (external) 1' has exceeded and the delay time has elapsed (see chap. 7.2.5).
13	overcurrent (external) 2 (Current triggering)	The corresponding output relay is activated when the limit value 'overcurrent (external) 2' has exceeded and the delay time has elapsed (see chap. 7.2.5).
14	overcurrent (earth/N) 1 (Current triggering)	The corresponding output relay is activated when the limit value 'overcurrent (earth- / neutral connector) 1' has exceeded and the delay time has elapsed (see chap. 7.2.6).
15	overcurrent (earth/N) 2 (Current triggering)	The corresponding output relay is activated when the limit value 'overcurrent (earth- / neutral connector) 2' has exceeded and the delay time has elapsed (see chap. 7.2.6).
16	thermal overcurrent (Current triggering)	The corresponding output relay is activated, when the limit value characteristic line 'thermal overcurrent' is exceeded and the delay time has elapsed (see chap. 7.2.7).
17	differential current OK (Current triggering)	The corresponding output relay is activated, when the limit values 'differential current 1' and 'differential current 2' are not active (see chap. 7.2.2).
18	stabilised current OK (Current triggering)	The corresponding output relay is activated, when the limit values 'overcurrent (stabilised) 1' and 'overcurrent (stabilised) 2' are not active (see chap. 7.2.3).
19	internal current OK (Current Triggering)	The corresponding output relay is activated, when the limit values overcurrent (internal) 1' and 'overcurrent (internal) 2' are not active (see chap. 7.2.4).

10



No.	Function	Description
20	external current OK (Current triggering)	The corresponding output relay is activated, when the limit values 'overcurrent (external) 1' and 'overcurrent (external) 2' are not active (see chap. 7.2.5).
21	earth-/neutral current OK (Current triggering)	The corresponding output relay is activated, when the limit values 'overcurrent (earth-/neutral connector) 1' and 'overcurrent (earth-/neutral connector) 2' are not active(see chap. 7.2.6).
22	underfrequency 1 (Frequency triggering)	The corresponding output relay is activated, when the limit value 'underfrequency 1' has fallen short and the delay time has elapsed (see chap. 7.2.8).
23	overfrequency 1 (Frequency triggering)	The corresponding output relay is activated, when the limit value 'overfrequency 1' is exceeded and the delay time has elapsed (see chap. 7.2.8).
24	underfrequency 2 (Frequency triggering)	The corresponding output relay is activated, when the limit value 'underfrequency 2' has fallen short and the delay time has elapsed (see chap. 7.2.8).
25	overfrequency 2 (Frequency triggering)	The corresponding output relay is activated, when the limit value 'overfrequency 2' is exceeded and the delay time has elapsed (see chap. 7.2.8).
26	frequency 1 OK (Frequency triggering)	The corresponding output relay is activated, when the limit values 'underfrequency 1' and overfrequency 1' (see chap. 7.2.8) are not active.
27	frequency 2 OK (Frequency triggering)	The corresponding output relay is activated, when the limit values 'underfrequency 2' and overfrequency 2' (see chap. 7.2.8) are not active.
28	underfrequency 1 or 2 (Frequency triggering)	The corresponding output relay is activated if one of the two limit values 'underfrequency 1' or 'underfrequency 2' is undershot and the delay time has elapsed (see chap. 7.2.8).
29	overfrequency 1 or 2 (Frequency triggering)	The corresponding output relay is activated if one of the two limit values 'overfrequency 1' or 'overfrequency 2' has been exceeded and the delay time has elapsed (see chap. 7.2.8).
30	Input E1 – KL2	The corresponding output relay is activated, when the digital input E1 at terminal 2 (see chap. 4.2.1 - Connection Diagram) is closed.
31	Input E2 – KL3	The corresponding output relay is activated, when the digital input E2 at terminal 3 (see chap. 4.2.1 - Connection Diagram) is closed.
32	Input E3 – KL4	The corresponding output relay is activated, when the digital input E3 at terminal 4 (see chap. 4.2.1 - Connection Diagram) is closed.
33	fault reset (digital inputs)	The corresponding output relay is energised, if the manual error reset function via digital input or ENT button is activated (see chap. 8.1).
34	global disable (digital inputs)	The corresponding output relay is energised, if the function 'global disable' via digital input (see chap. 8.1) is activated.
35	time lock active (digital inputs)	The corresponding output relay is activated as long as the internal locking time expires after activation by a parameterised input.
36	disable 1 (digital inputs)	The corresponding output relay is energised, if the function 'disable 1' via digital input (see chap. 8.1) is activated.
37	disable 2 (digital inputs)	The corresponding output relay is energised, if the function 'disable 2' via digital input (see chap. 8.1) is activated.
38	feedback A1 (digital inputs)	The corresponding output relay is energised, if the function 'feedback A1' via digital input (see chap. 8.1) is activated.
39	feedback A2 (digital inputs)	The corresponding output relay is energised, if the function 'feedback A2' via digital input (see chap. 8.1) is activated.
40	feedback A3 (digital inputs)	The corresponding output relay is energised, if the function 'feedback A3' via digital input (see chap. 8.1) is activated.
41	feedback A4 (digital inputs)	The corresponding output relay is energised, if the function 'feedback A4' via digital input (see chap. 8.1) is activated.
42	feedback A5 (digital inputs)	The corresponding output relay is energised, if the function 'feedback A5' via digital input (see chap. 8.1) is activated.
43	switch point 1 (programmable switching points)	The corresponding output relay is activated, when the function 'switch point 1' (see chap. 7.4 - Programmable Switch Points) has exceeded or undershot the set limit value and the delay time has elapsed.
44	switch point 2 (programmable switching points)	The corresponding output relay is activated, when the function 'switch point 2' (see chap. 7.4 - Programmable Switch Points) has exceeded or undershot the set limit value and the delay time has elapsed.
45	switch point 3 (programmable switching points)	The corresponding output relay is activated, when the function 'switch point 3' (see chap. 7.4 - Programmable Switch Points) has exceeded or undershot the set limit value and the delay time has elapsed.



No.	Function	Description
46	logic 1 (logic functions)	The corresponding output relay is activated, if the function 'logic 1' (see <i>chap. 10 - Logic Functions</i>) has the output value 'true'.
47	logic 2 (logic functions)	The corresponding output relay is activated, if the function 'logic 2' (see <i>chap. 10 - Logic Functions</i>) has the output value 'true'.
48	logic 3 (logic functions)	The corresponding output relay is activated, if the function 'logic 3' (see <i>chap. 10 - Logic Functions</i>) has the output value 'true'.
49	logic 4 (logic functions)	The corresponding output relay is activated, if the function 'logic 4' (see <i>chap. 10 - Logic Functions</i>) has the output value 'true'.
50	logic 5 (logic functions)	The corresponding output relay is activated, if the function 'logic 5' (see <i>chap. 10 - Logic Functions</i>) has the output value 'true'.
51	timer 1 (logic functions)	The corresponding output relay is activated, if the function 'timer 1' (see <i>chap. 10 - Logic Functions</i>) has the output value 'true'.
52	timer 2 (logic functions)	The corresponding output relay is activated, if the function 'timer 2' (see <i>chap. 10 - Logic Functions</i>) has the output value 'true'.
53	O1 REL1	The corresponding output relay is activated, when the output relay 1 is energised.
54	O2 REL2	The corresponding output relay is activated, when the output relay 2 is energised.
55	O3 REL3	The corresponding output relay is activated, when the output relay 3 is energised.
56	O4 REL4	The corresponding output relay is activated, when the output relay 4 is energised.
57	O5 REL5	The corresponding output relay is activated, when the output relay 5 is energised.

10 Logic Functions

The DSR-8 is equipped with 5 programmable logic modules. The following functions are available:

- AND gate (AND)
- OR gate (OR)
- EXCLUSIVE OR gate (XOR)
- AND NOT gate (NAND)
- OR NOT gate (NOR)
- EXCLUSIVE NOT OR gate (XNOR)
- Timer – pick up delayed
- Timer – drop out delayed

10

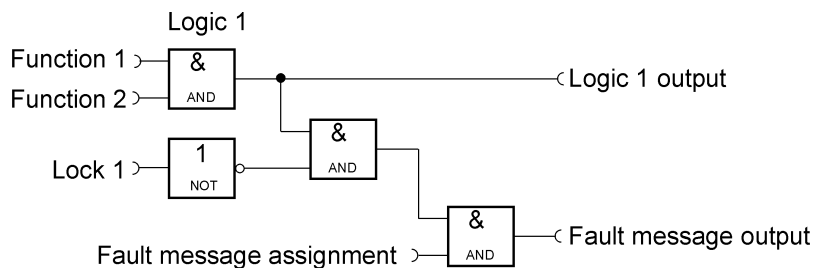

All logic and timer functions can be assigned to the fault message groups and to the central fault. The available locking functions are also available for all logic and timer functions. Each input function is invertible.

The output of each logic function can be set to an internal input flag. For a list of all available input functions see chap. 8.1 – Digital Inputs.



10.1 AND – Gate (1)

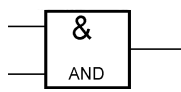

E1	E2	A
0	0	0
0	1	0
1	0	0
1	1	1

2 parameterisable inputs are logical 'AND' linked.

10.2 OR – Gate (2)

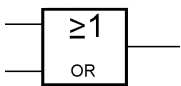

E1	E2	A
0	0	0
0	1	1
1	0	1
1	1	1

2 parameterisable inputs are logical 'OR' linked.

10.3 Exclusive OR – Gate (3)

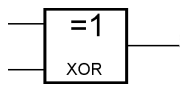

E1	E2	A
0	0	0
0	1	1
1	0	1
1	1	0

2 parameterisable inputs are logical 'EXCLUSIVE OR' linked.

10.4 AND-Not – Gate (4)

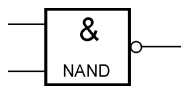

E1	E2	A
0	0	1
0	1	1
1	0	1
1	1	0

2 parameterisable inputs are logical 'AND NOT' linked.

10.5 OR-Not – Gate (5)

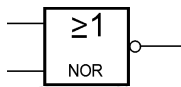

E1	E2	A
0	0	1
0	1	0
1	0	0
1	1	0

2 parameterisable inputs are logical 'OR NOT' linked.

10.6 Exclusive Not-OR – Gate (6)

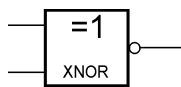

E1	E2	A
0	0	1
0	1	0
1	0	0
1	1	1

2 parameterisable inputs are logical 'EXCLUSIVE NOT OR' linked.

10.7 Timer – pick up delayed

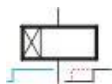

switch on delay time

If the input signal is active, the output of the timer only switches after the set delay time has elapsed (example figured left: 1,0 s).

10.8 Timer – drop down delayed

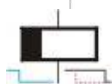

switch off delay time

After drop out of the input signal, the output of the timer switches off only after the set delay time has elapsed (example figured left: 1,0 s).



10.9 Fault Message Assignment

central fault
 central fault 1
 central fault 2

All logic and timer functions can be assigned to the 'central fault', 'central fault 1' and 'central fault 2'.

10.10 Locking Functions and Automatic Reset

automatic reset

disable limit value

time lock
 trip lock 1
 trip lock 2
 disable all

For all logic and timer functions, the fault messaging behavior can be set to automatic reset and the available locking functions can be activated in order to suppress a fault message if necessary. The logic and timer functions are executed independently of this.

10.11 Functions for the Logic Modules

The digital output functions (see chap. 9.1) are available as input functions for all logic and timer functions. The following functions additionally are available:

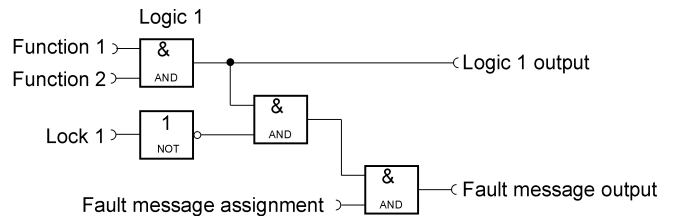

No.	Function	Description
53	A1 REL1 – KL8/ 9	The input of the logic is true when output A1 is set.
54	A2 REL2 – KL8/ 10	The input of the logic is true when output A2 is set.
55	A3 REL3 – KL8/ 11	The input of the logic is true when output A3 is set.
56	A4 REL4 – KL8/ 12	The input of the logic is true when output A4 is set.
57	A5 REL5 – KL13/ 14/ 15	The input of the logic is true when output A5 is set.

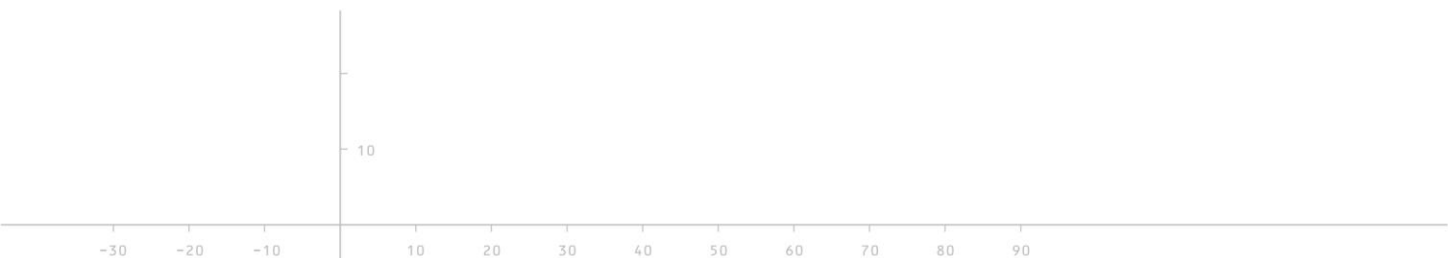



11 Technical Data



Assembly and putting into operation only by trained professionals
Connecting in compliance with VDE 0160

Auxiliary voltage	24 V DC (18 ... 36 V); 230 V AC / 12 V DC on customers request
Power consumption	approx. 4 W at 24 V DC, approx. 6 VA at 230 V AC
Digital inputs	low active (contact voltage 12 V DC, 5 mA, opto-decoupled), cables not longer than 3 m
Relay outputs	230 V / 50 cy / 2 A - 1 neutral changeover contact (A5) - 4 normally open contacts with common root (A1 – A4)
Current measuring range	approx. 0.03 up to 4.0 A AC (1 A Version) approx. 0.12 up to 20.0 A AC (5 A Version) tolerance < 0,2 % end of value
Frequency measuring range	15.0 cy up to 100.0 cy starts with approx. 150 mA current measured accuracy < 0.01 cy
Climatic conditions:	according to DIN EN 60255-1 (09-2055)
Ambient temperature in operation	-20 °C ... +55 °C
transport and storage	-25 °C ... +55 °C
Housing dimensions	W / H / D : 100 x 75 x 110 mm mounting on 35 mm top-hat rail according to DIN EN 60715

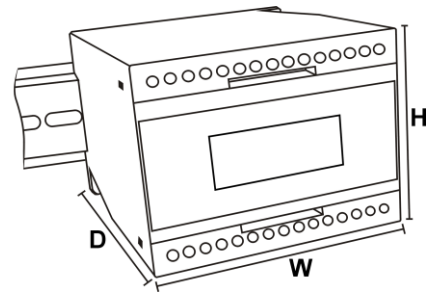

11.1 Triggering Values

	Setting range	Resolution	Repeatability	Minimum triggering delay
Differential current	1 up to 199 % nominal current	0.1 %	< 0.1 %	< 60 ms typ. 48 ms
Overcurrent	10 up to 399 % nominal current	0.1 %	< 0.1 %	< 60 ms typ. 48 ms
Over- / underfrequency	35.0 ... 65.0 cy	0.01 cy	< 0.01 cy	< 60 ms typ. 48 ms

11

11.2 Ordering Information

Differential Current Relay DSR-8	Part number
1 A I_{Nom} / 24 V DC auxiliary voltage:	E1988
5 A I_{Nom} / 24 V DC auxiliary voltage:	E1990
Accessories	
Parameterisation cable USB A: USB Mini 1,5 m	KC0215
Parameterisation cable USB A: USB Mini 3,0 m	KC0329
Current transformers, various ratios e.g. 200 A / 5 A	on request





12 Connection Example

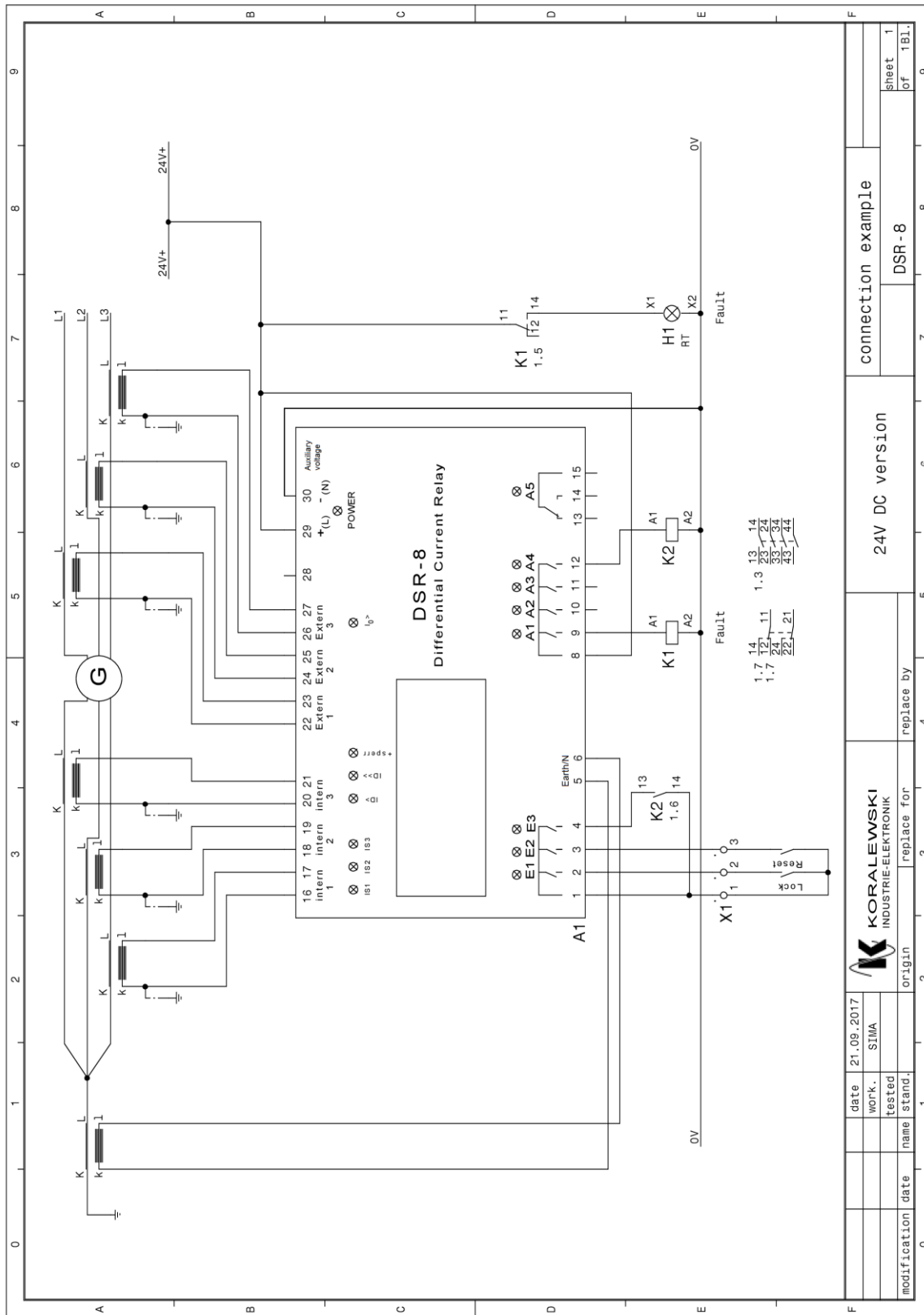

date	21.09.2017	work.	SIMA	tested		replace by		replace for		origin		24V DC version	connection example	sheet 1 of 1BL.
modification	date	name	stand.									DSR-8		



Annex 1 Parameter Groups

Annex 1.1 Configuration (Konfig. / Config – Group 1)

The parameter group 1 contains two parameters per subgroup (*refer to chap. 6.8.1*). The following settings are available:

Parameter	Description	Setting range	Default	
1.6.1 1.6.2	PIN protection	Entering 4-digit PIN Code activates the PIN protection	0001 ... 9999 1 / 0 (on / off)	0001 off (0)
1.10.1 1.10.2	Nominal current	Nominal current of system in xxxxx.x Ampere without function	1,0 ... 999,999.9 A -	1000.0 A 0
1.12.1 1.12.2	Nominal frequency	Nominal frequency of system, 50 or 60 cy without function	0 / 255 (50 / 60 cy) -	50 cy (0) 0
1.13.1 1.13.2	Transformer primary voltage	Primary voltage of transformer in xxxxxx Volt without function	1 ... 999,999 V -	400 V 0
1.14.1 1.14.2	Transformer secondary voltage	Secondary voltage of transformer in xxxxxx Volt without function	1 ... 999,999 V -	230 V 0
1.15.1 1.15.2	Protection area	Type of the system (<i>see chap. 6.1</i>) without function	0 ... 7 -	GEN (0) 0
1.16.1 1.16.2	First fault display	Activating of first fault display only (<i>see chap. 7.1.8</i>) without function	255 / 0 (on / off) -	off (0) 0
1.17.1 1.17.2	Number format	Selection of current display format (<i>see chap. 6.5</i>) without function	0 ... 5 -	auto. (0) 0
1.18.1 1.18.2	Default display	Selecting the main screen without function	0 ... 3 -	I _{Stab} rel. (2) 0
1.19.1 1.19.2	Return to default	Switching back to standard display in x sec. without function	0 ... 600 sec. -	60 sec. 0
1.20.1 1.20.2	Brightness max.	Maximum brightness of the lighting in % without function	50 ... 100 % -	100 % 0
1.21.1 1.21.2	Brightness min.	Minimum brightness of the lighting in % without function	0 ... 50 % -	10 % 0
1.22.1 1.22.2	Screensaver time	Time until activating brightness min. in x sec. without function	0 ... 600 sec. -	60 sec. 0
1.24.1 1.24.2	Trip lock time	Locking time for trippings in xxx seconds Coding lock time active cancel overcurrent	0 ... 600 sec.	30 sec. 10
1.25.1 1.25.2	Correction factor L ₁₁	Correction factor current transformer internal L1 in x.xxx without function	0.5 ... 1.5 -	1.000 -
1.26.1 1.26.2	Correction factor L ₁₂	Correction factor current transformer internal L2 in x.xxx without function	0.5 ... 1.5 -	1.000 -
1.27.1 1.27.2	Correction factor L ₁₃	Correction factor current transformer internal L3 in x.xxx without function	0.5 ... 1.5 -	1.000 -
1.28.1 1.28.2	Correction factor L _{E1}	Correction factor current transformer external L1 in x.xxx without function	0.5 ... 1.5 -	1.000 -
1.29.1 1.29.2	Correction factor L _{E2}	Correction factor current transformer external L2 in x.xxx without function	0.5 ... 1.5 -	1.000 -

10

Differential Current Relay DSR-8

DSR-8 | Status 2017 - 09 - 19



Parameter		Description	Setting range	Default
1.30.1 1.30.2	Correction factor I_{E3}	Correction factor current transformer external L3 in x.xxx without function	0.5 ... 1.5 -	1.000 -
1.31.1 1.31.2	Correction factor $I_{Earth/N}$	Correction factor converter Earth/N in x.xxx without function	0.5 ... 1.5 -	1.000 -
1.32.1 1.32.2	Phase shift transformer	Phase shift in xxx ° without function	0 ... 359 ° -	150 ° -
1.33.1 1.33.2	Current transformer Internal Primary	Primary internal converter current in xxxxxx A without function	0 ... 1000000 A -	1000 A -
1.34.1 1.34.2	Current transformer Internal Secondary	Secondary internal converter current in xx A without function	1 / 5 A -	5 A -
1.35.1 1.35.2	Current transformer External Primary	Primary external converter current in xxxxxx A without function	0 ... 1000000 A -	1000 A -
1.36.1 1.36.2	Current transformer External Secondary	Secondary external converter current in xx A without function	1 / 5 A -	5 A -
1.37.1 1.37.2	Current transformer Earth / N primary	Primary converter current Earth / N in xxxxxx A without function	0 ... 1000000 A -	1000 A -
1.38.1 1.38.2	Current transformer Earth / N secondary	Secondary converter current Earth / N in xx A without function	1/5 A -	5 A -





Annex 1.2 Limit Values (Grenzwerte / Limits – Group 4)

The parameter group 4 contains four parameters per subgroup (*refer to chap. 6.8.1*). The following settings are available:

Parameter	Description	Setting range	Default
4.1.1 4.1.2 4.1.3 4.1.6	differential current 1 Trigger switching point in xxx.x % Switch-back Hysteresis in xxx.x % Triggering delay in xx.xx sec. Coding of fault message behaviour	1.0 ... 199.9 % 0.5 ... 50.0 % 0.05 ... 999.99 sec. (see chap. 6.8.3)	10.0 % 1.0 % 5.00 sec. activated / auto-reset (1000000000001001)
4.2.1 4.2.2 4.2.3 4.2.6	differential current 2 Trigger switching point in xxx.x % Switch-back Hysteresis in xxx.x % Triggering delay in xx.xx sec. Coding of fault message behaviour	1.0 ... 199.9 % 0.5 ... 50.0 % 0.05 ... 999.99 sec. (see chap. 6.8.3)	20.0 % 1.0 % 0.08 sec. activated / auto-reset (1000000000001001)
4.3.1 4.3.2	differential current parametrical curve Break point in xxx.x % Slope in xxx.x (<i>refer chap. 7.2.2</i>)	1.0 ... 399.9 % 0.0 ... 399.9 %	100.0 % 10.0 %
4.4.1 4.4.2 4.4.3 4.4.6	differential current rate of change Trigger switching point in xxx.x %/s Switch-back Hysteresis in xxx.x % Triggering delay in xx.xx sec. Coding of fault message behaviour	1.0 ... 199.9 %/s 0.5 ... 50.0 % 0.05 ... 999.99 sec. (see chap. 6.8.3)	100.0 %/s 0.5 % 0.10 sec. activated / auto-reset (1000000000001001)
4.5.1 4.5.2 4.5.3 4.5.6	overcurrent (stabilised) 1 Trigger switching point in xxx.x % Switch-back Hysteresis in xxx.x % Triggering delay in xx.xx sec. Coding of fault message behaviour	10.0 ... 399.9 % 0.5 ... 50.0 % 0.05 ... 999.99 sec. (see chap. 6.8.3)	100.0 % 1.0 % 1.00 sec. activated / auto-reset (1000000000001001)
4.6.1 4.6.2 4.6.3 4.6.6	overcurrent (stabilised) 2 Trigger switching point in xxx.x % Switch-back Hysteresis in xxx.x % Triggering delay in xx.xx sec. Coding of fault message behaviour	10.0 ... 399.9 % 0.5 ... 50.0 % 0.05 ... 999.99 sec. (see chap. 6.8.3)	200.0 % 0.5 % 0.50 sec. activated / auto-reset (1000000000001001)
4.7.1 4.7.2 4.7.3 4.7.6	overcurrent (internal) 1 Trigger switching point in xxx.x % Switch-back Hysteresis in xxx.x % Triggering delay in xx.xx sec. Coding of fault message behaviour	10.0 ... 399.9 % 0.5 ... 50.0 % 0.05 ... 999.99 sec. (see chap. 6.8.3)	100.0 % 1.0 % 1.00 sec. activated / auto-reset (1000000000001001)
4.8.1 4.8.2 4.8.3 4.8.6	overcurrent (internal) 2 Trigger switching point in xxx.x % Switch-back Hysteresis in xxx.x % Triggering delay in xx.xx sec. Coding of fault message behaviour	10.0 ... 399.9 % 0.5 ... 50.0 % 0.05 ... 999.99 sec. (see chap. 6.8.3)	200.0 % 0.5 % 0.50 sec. activated / auto-reset (1000000000001001)
4.9.1 4.9.2 4.9.3 4.9.6	overcurrent (external) 1 Trigger switching point in xxx.x % Switch-back Hysteresis in xxx.x % Triggering delay in xx.xx sec. Coding of fault message behaviour	10.0 ... 399.9 % 0.5 ... 50.0 % 0.05 ... 999.99 sec. (see chap. 6.8.3)	100.0 % 0.5 % 1.00 sec. activated / auto-reset (1000000000001001)
4.10.1 4.10.2 4.10.3 4.10.6	overcurrent (external) 2 Trigger switching point in xxx.x % Switch-back Hysteresis in xxx.x % Triggering delay in xx.xx sec. Coding of fault message behaviour	10.0 ... 399.9 % 0.5 ... 50.0 % 0.05 ... 999.99 sec. (see chap. 6.8.3)	200.0 % 0.5 % 0.50 sec. activated / auto-reset (1000000000001001)
4.11.1 4.11.2 4.11.3 4.11.6	overcurrent (earth / N) 1 Trigger switching point in xxx.x % Switch-back Hysteresis in xxx.x % Triggering delay in xx.xx sec. Coding of fault message behaviour	10.0 ... 399.9 % 0.5 ... 50.0 % 0.05 ... 999.99 sec. (see chap. 6.8.3)	10.0 % 1.0 % 1.00 sec. activated / auto-reset (1000000000001001)
4.12.1 4.12.2 4.12.3 4.12.6	overcurrent (earth / N) 2 Trigger switching point in xxx.x % Switch-back Hysteresis in xxx.x % Triggering delay in xx.xx sec. Coding of fault message behaviour	10,0 ... 399,9 % 0.5 ... 50.0 % 0.05 ... 999.99 sec. (see chap. 6.8.3)	20.0 % 0.5 % 0.50 sec. activated / auto-reset (1000000000001001)

10



Parameter	Description	Setting range	Default
4.13.1 4.13.2 4.13.6	overcurrent time protection Selection of the characteristic line Time multiplier in xx.xx sec. Coding of fault message behaviour	0 ... 11 0.05 ... 15.00 sec. (see chap. 6.8.3)	1 1.00 sec. auto-reset (0000000000001001)
4.14.1 4.14.2 4.14.3 4.14.6	underfrequency 1 Trigger switching point in xx.xx cy Switch-back Hysteresis in x.xx cy Triggering delay in xx.xx sec. Coding of fault message behaviour	35.00 ... 75.00 cy 0.05 ... 2.00 cy 0.05 ... 999.99 sec. (see chap. 6.8.3)	49.20 cy 0.10 cy 0.30 sec. activated / auto-reset (1000000000001001)
4.15.1 4.15.2 4.15.3 4.15.6	overfrequency 1 Trigger switching point in xx.xx cy Switch-back Hysteresis in x.xx cy Triggering delay in xx.xx sec. Coding of fault message behaviour	35.00 ... 75.00 cy 0.05 ... 2.00 cy 0.05 ... 999.99 sec. (see chap. 6.8.3)	50.80 cy 0.10 cy 0.30 sec. activated / auto-reset (1000000000001001)
4.16.1 4.16.2 4.16.3 4.16.6	underfrequency 2 Trigger switching point in xx.xx cy Switch-back Hysteresis in x.xx cy Triggering delay in xx.xx sec. Coding of fault message behaviour	35.00 ... 75.00 cy 0.05 ... 2.00 cy 0.05 ... 999.99 sec. (see chap. 6.8.3)	48.00 cy 0.50 cy 0.08 sec. activated / auto-reset (1000000000001001)
4.17.1 4.17.2 4.17.3 4.17.6	overfrequency 2 Trigger switching point in xx.xx cy Switch-back Hysteresis in x.xx cy Triggering delay in xx.xx sec. Coding of fault message behaviour	35.00 ... 75.00 cy 0.05 ... 2.00 cy 0.05 ... 999.99 sec. (see chap. 6.8.3)	52.00 cy 0.50 cy 0.08 sec. activated / auto-reset (1000000000001001)
4.18.1 4.18.6	rotary field protection Rotary field right or left Coding of fault message behaviour	1 / 0 (left / right) (see chap. 6.8.3)	right (0) de-activated (0000000000000001)
4.19.1 ... 4.19.6	not assigned		
4.20.1 4.20.2 4.20.3 4.20.7	switch point 1 Trigger switching point in xx.x % Switch-back Hysteresis in xx.x % Triggering delay in xx.xx sec. Coding of fault message behaviour	0.1 ... 399.0 % 0.5 ... 50.0 % 0.05 ... 999.99 sec. (see chap. 6.8.3)	100.0 % 2.0 % 1.00 sec. 0 (without function)
4.21.1 4.21.2 4.21.3 4.21.7	switch point 2 Trigger switching point in xx.x % Switch-back Hysteresis in xx.x % Triggering delay in xx.xx sec. Coding of fault message behaviour	0.1 ... 399.0 % 0.5 ... 50.0 % 0.05 ... 999.99 sec. (see chap. 6.8.3)	100.0 % 2.0 % 1.00 sec. 0 (without function)
4.22.1 4.22.2 4.22.3 4.22.7	switch point 3 Trigger switching point in xx.x % Switch-back Hysteresis in xx.x % Triggering delay in xx.xx sec. Coding of fault message behaviour	0.1 ... 399.0 % 0.5 ... 50.0 % 0.05 ... 999.99 sec. (see chap. 6.8.3)	100.0 % 2.0 % 1.00 sec. 0 (without function)
4.23.1 ... 4.24.6	not assigned		

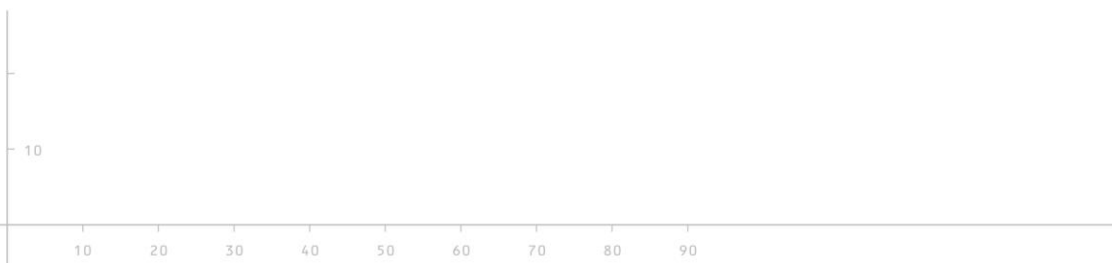



Annex 1.4 Digital Outputs (Digi. Ausg. / OUT – Group 6)

The parameter group 6 contains three parameters per subgroup (refer to chap. 6.8.2). The following settings are available:

Parameter	Description	Setting range	Default
6.1.1 6.1.2 6.1.3	A1 / Relay 1, terminal KL8/ 9	Function Switching behaviour Pulse duration (min.)	differential current 1 (6) Open circuit principle (0) 2.0 sec.
6.2.1 6.2.2 6.2.3	A2 / Relay 2, terminal KL8/ 10	Function Switching behaviour Pulse duration (min.)	differential current 2 (7) Open circuit principle (0) 2.0 sec.
6.3.1 6.3.2 6.3.3	A3 / Relay 3, terminal KL8/ 11	Function Switching behaviour Pulse duration (min.)	underfrequency 1 (22) Open circuit principle (0) 2.0 sec.
6.4.1 6.4.2 6.4.3	A4 / Relay 4, terminal KL8/ 12	Function Switching behaviour Pulse duration (min.)	overfrequency 1 (23) Open circuit principle (0) 2.0 sec.
6.5.1 6.5.2 6.5.3	A5 / Relay 5, terminals KL 14-15	Function Switching behaviour Pulse duration (min.)	central fault (2) Open circuit principle (0) 2.0 sec.
6.6.1 6.6.2 6.6.3	without function	--	--

Annex 1.5 Digital Inputs (Digi. Eing. / IN – Group 7)

The parameter group 7 contains two parameters per subgroup 7 (refer to chap. 6.8.2). The following settings are available:

Parameter	Description	Setting range	Default
7.1.1 7.1.2	E1 / terminal KL 2	Function Switching behaviour	global disable (1) Open circuit principle (0)
7.2.1 7.2.2	E2 / terminal KL 3	Function Switching behaviour	locking time set (3) Open circuit principle (0)
7.3.1 7.3.2	E3 / terminal KL 4	Function Switching behaviour	fault reset (6) Open circuit principle (0)

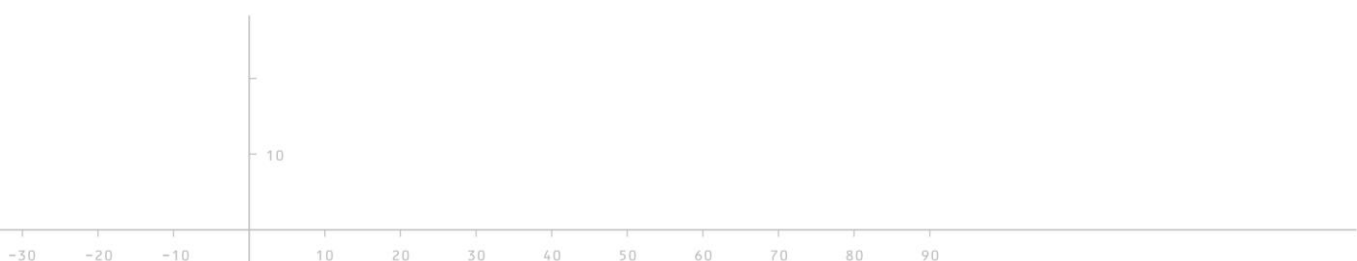



Annex 1.6 Logic Functions (Logik – Group 10)

The parameter group 10 contains six respectively five parameters per subgroup (refer to chap. 10). The following settings are available:

Parameter	Description	Setting range	Default
10.1.1	Function E1	0 ... 57 (see chap. 9.1)	0 (without Function)
10.1.2	1 / 0 (inverted / normally)	0 or 1	0 (normally)
10.1.3	Function E2	0 ... 57 (see chap. 9.1)	0 (without Function)
10.1.4	1 / 0 (inverted / normally)	0 or 1	0 (normally)
10.1.5	Logic function	0 ... 6 (see chap. 10)	0 (without Function)
10.1.7	Coding of fault message behaviour	(see chap. 6.8.3)	auto-reset (1000000000001001)
10.1.8	Internal assignment	0 ... 12 (see chap. 8.1)	0 (without Function)
10.2.1	Function E1	0 ... 57 (see chap. 9.1)	0 (without Function)
10.2.2	1 / 0 (inverted / normally)	0 or 1	0 (normally)
10.2.3	Function E2	0 ... 57 (see chap. 9.1)	0 (without Function)
10.2.4	1 / 0 (inverted / normally)	0 or 1	0 (normally)
10.2.5	Logic function	0 ... 6 (see chap. 10)	0 (without Function)
10.2.7	Coding of fault message behaviour	(see chap. 6.8.3)	auto-reset (1000000000001001)
10.2.8	Internal assignment	0 ... 12 (see chap. 8.1)	0 (without Function)
10.3.1	Function E1	0 ... 57 (see chap. 9.1)	0 (without Function)
10.3.2	1 / 0 (inverted / normally)	0 or 1	0 (normally)
10.3.3	Function E2	0 ... 57 (see chap. 9.1)	0 (without Function)
10.3.4	1 / 0 (inverted / normally)	0 or 1	0 (normally)
10.3.5	Logic function	0 ... 6 (see chap. 10)	0 (without Function)
10.3.7	Coding of fault message behaviour	(see chap. 6.8.3)	auto-reset (1000000000001001)
10.3.8	Internal assignment	0 ... 12 (see chap. 8.1)	0 (without Function)
10.4.1	Function E1	0 ... 57 (see chap. 9.1)	0 (without Function)
10.4.2	1 / 0 (inverted / normally)	0 or 1	0 (normally)
10.4.3	Function E2	0 ... 57 (see chap. 9.1)	0 (without Function)
10.4.4	1 / 0 (inverted / normally)	0 or 1	0 (normally)
10.4.5	Logic function	0 ... 6 (see chap. 10)	0 (without Function)
10.4.7	Coding of fault message behaviour	(see chap. 6.8.3)	auto-reset (1000000000001001)
10.4.8	Internal assignment	0 ... 12 (see chap. 8.1)	0 (without Function)
10.5.1	Function E1	0 ... 57 (see chap. 9.1)	0 (without Function)
10.5.2	1 / 0 (inverted / normally)	0 or 1	0 (normally)
10.5.3	Function E2	0 ... 57 (see chap. 9.1)	0 (without Function)
10.5.4	1 / 0 (inverted / normally)	0 or 1	0 (normally)
10.5.5	Logic function	0 ... 6 (see chap. 10)	0 (without Function)
10.5.7	Coding of fault message behaviour	(see chap. 6.8.3)	auto-reset (1000000000001001)
10.5.8	Internal assignment	0 ... 12 (see chap. 8.1)	0 (without Function)
10.6.1	Function input	0 ... 57 (see chap. 9.1)	0 (without Function)
10.6.2	1 / 0 (inverted / normally)	0 or 1	0 (normally)
10.6.5	Timer function (pick-up/drop-out delay)	0 or 1	1 (pick-up delay)
10.6.6	Timer duration	0.0 ... 6000.0 sec.	1.0 sec.
10.6.7	Coding of fault message behaviour	(see chap. 6.8.3)	auto-reset (1000000000001001)
10.6.8	Internal assignment	0 ... 12 (see chap. 8.1)	0 (without Function)
10.7.1	Function input	0 ... 57 (see chap. 9.1)	0 (without Function)
10.7.2	1 / 0 (inverted / normally)	0 or 1	0 (normally)
10.7.5	Timer function (pick-up/drop-out delay)	0 or 1	1 (pick-up delay)
10.7.6	Timer duration	0.0 ... 6000.0 sec.	1.0 sec.
10.7.7	Coding of fault message behaviour	(see chap. 6.8.3)	auto-reset (1000000000001001)
10.7.8	Internal assignment	0 ... 12 (see chap. 8.1)	0 (without Function)

10



Annex 2 Overcurrent-Time-Protection Curves

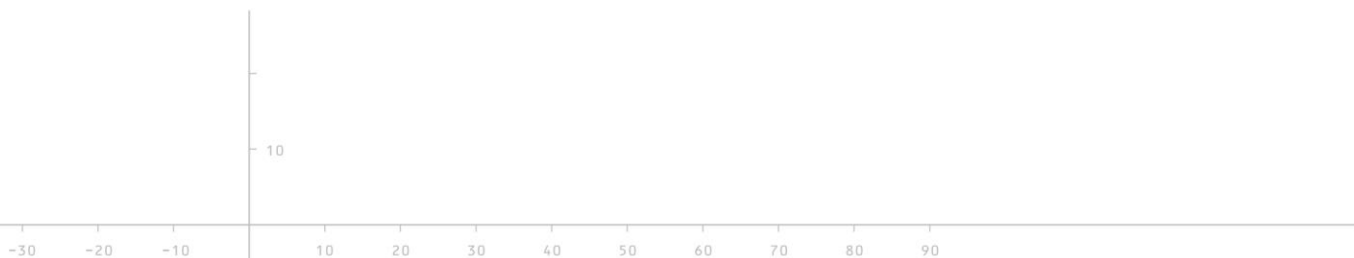
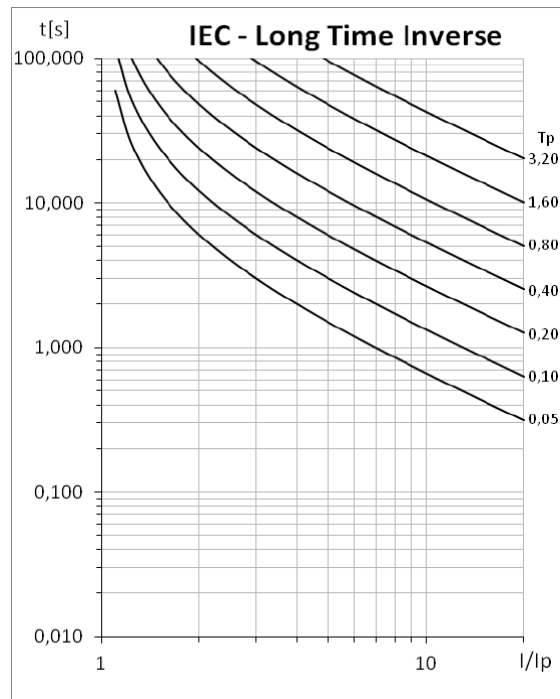
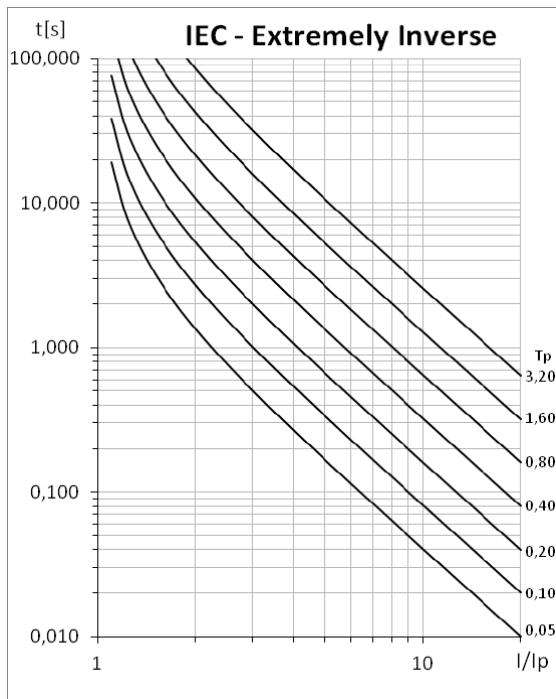
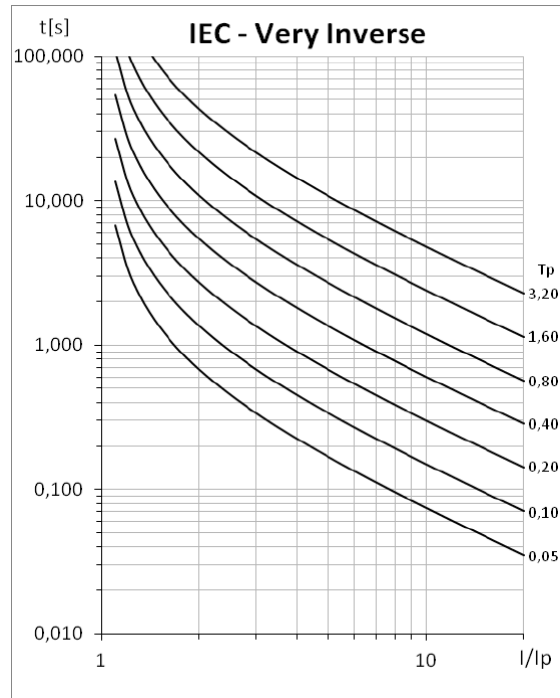
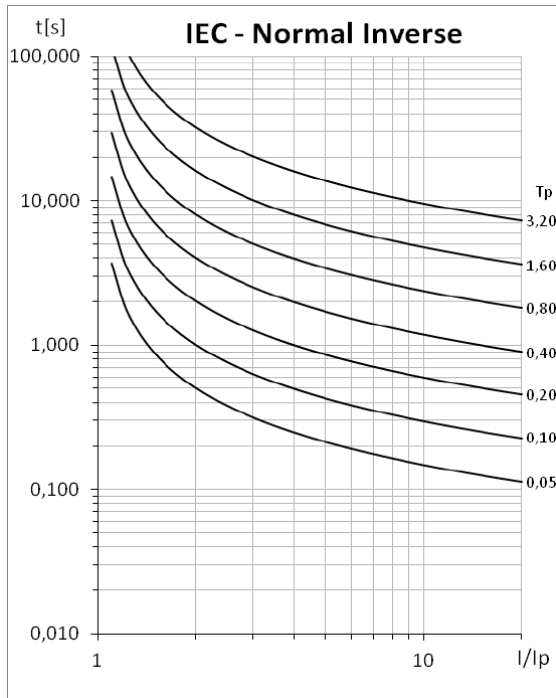

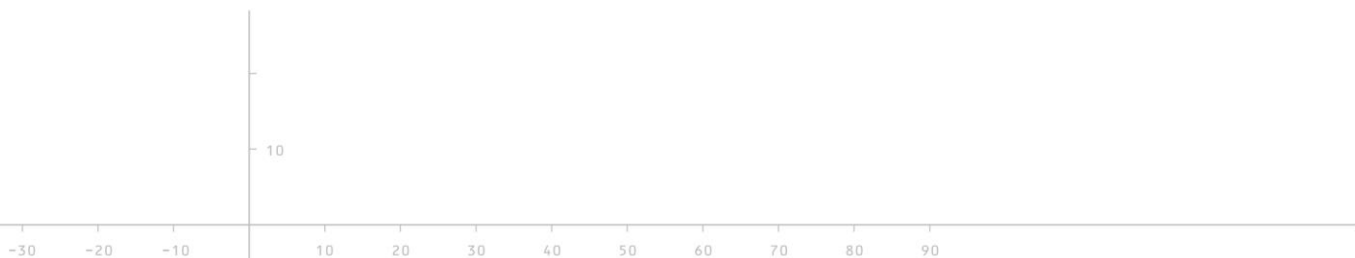
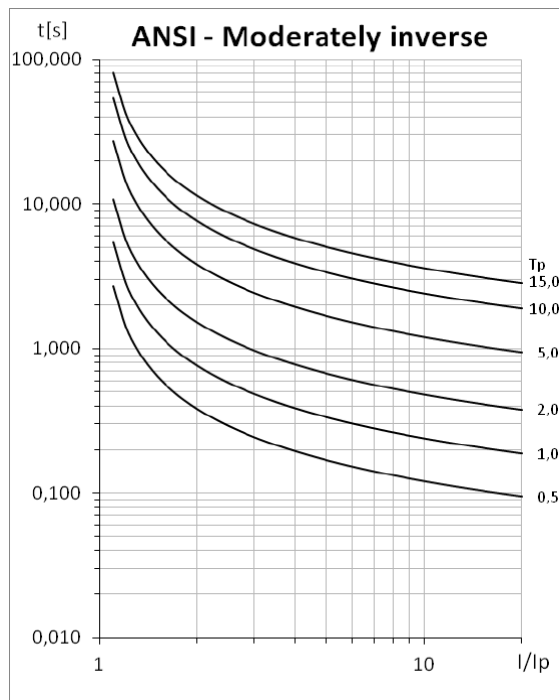
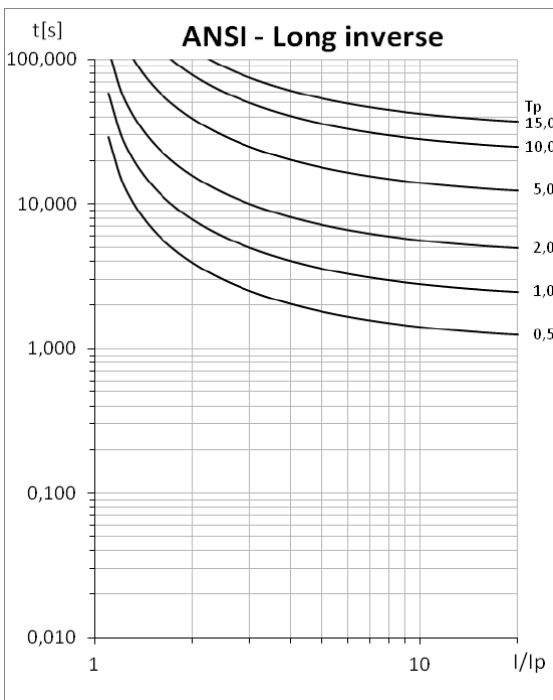
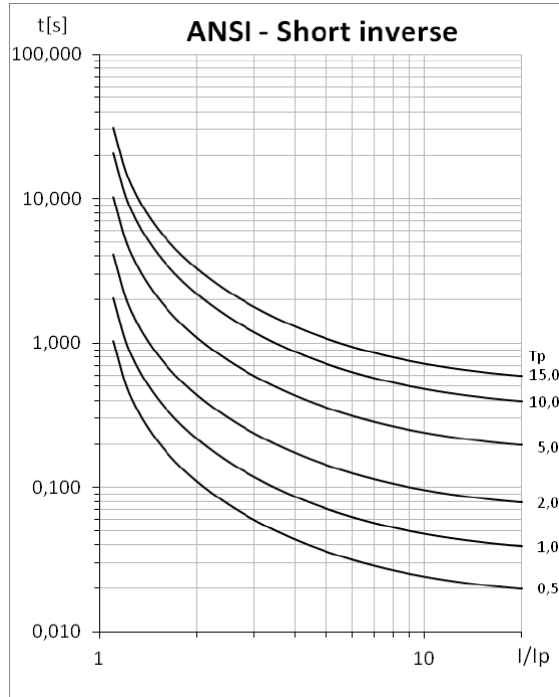
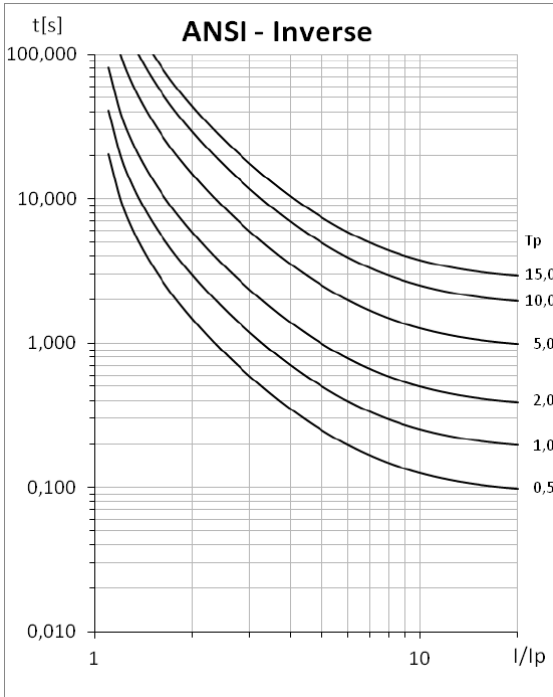

Differential Current Relay DSR-8

DSR-8 | Status 2017 - 09 - 19

